



Touch One-door Access Controller



Model:YK-968

YLI ELECTRONIC

TECHNICAL PARAMETERS

NO	ITEM	PARAMETER
1	Operating voltage	DC 12V±10%
2	Operating current	< 100mA
3	Dimensions	120mm x78mm x22mm
4	Weight	130g
5	Ambient temperature	-10℃ — 70℃
6	Relative humidity	20%—80%
7	Storage	1000 users
8	Card type (alternative)	EM(ID) card(IC card for option)
9	Card reading distance	1—15CM

FACTORY DEFAULT SETTINGS

Programming Password	123456
Open Mode	Card or Access PIN
Output signal time	5secs
Backlight	Auto
Security function	Off
WG26Port	Input

LED AND BUZZER INDICATES

Fast flash: light on 0.5sec,light off 0.5 sec Slow flash:light on 0.1 sec,light off 0.1sec

Standby State	Red light(SlowFlash)
Unlocked state	GreenLight(FastFlash)
Read card to open (Enter password then press "#")	ValidCard:Greenlightkeepson,1 shortbuzz InvalidCard:3 shortbuzz
Enter Access PIN to open	Correct Password:Greenlightkeepson,1 shortbuzz Incorrect Password:3 shortbuzz
Card+AccessPin (After Read card to enter Access Pin, then Press "#")	InvalidCard:3 shortbuzz ValidCard:GreenlightFastflash Correct Password:Greenlightkeepson,1 shortbuzz Incorrect Password:3 shortbuzz

Programming operating state indication(Take the programming operating of adding Users for example)

Steps	sound and light hint
#	GreenlightFastflash,1shortbuzz
123456#	CorrectPassword:Redlightkeepson,1 shortbuzz WrongPassword:3shortbuzz
1 Read Card	GreenlightFastflash:1longbuzz indicate can add cards,3 shortbuzz indicate can't add cards
#	Input correct:1longbuzz Input wrong:3shortbuzz,Redlightslowflash,Meanwhile Exit programming state

INSTALLING WIRING DIAGRAM

Jp1

No.	SILKPRINT	COLOR	FUNCTION
1	12V	Red	DC 12V Input
2	GND	Black	Power
3	PUSH	Blue	Low-level output
4	OPEN	Yellow	Door Release
5	BELL	Gray	BELL
6	BELL	White	

Jp2

NO	SILKPRINT	COLOR	FUNCTION	NOTE
1	12V	Red	DC 12V Output	Some models without this interface
2	GND	Black	Power	
3	DATA0	Green	WG dataline0	
4	DATA1	White	WG dataline1	
5	NC	Brown	Relay NC Output	
6	COM	Blue	Relay Com output	
7	NO	Purple	Relay NO Output	

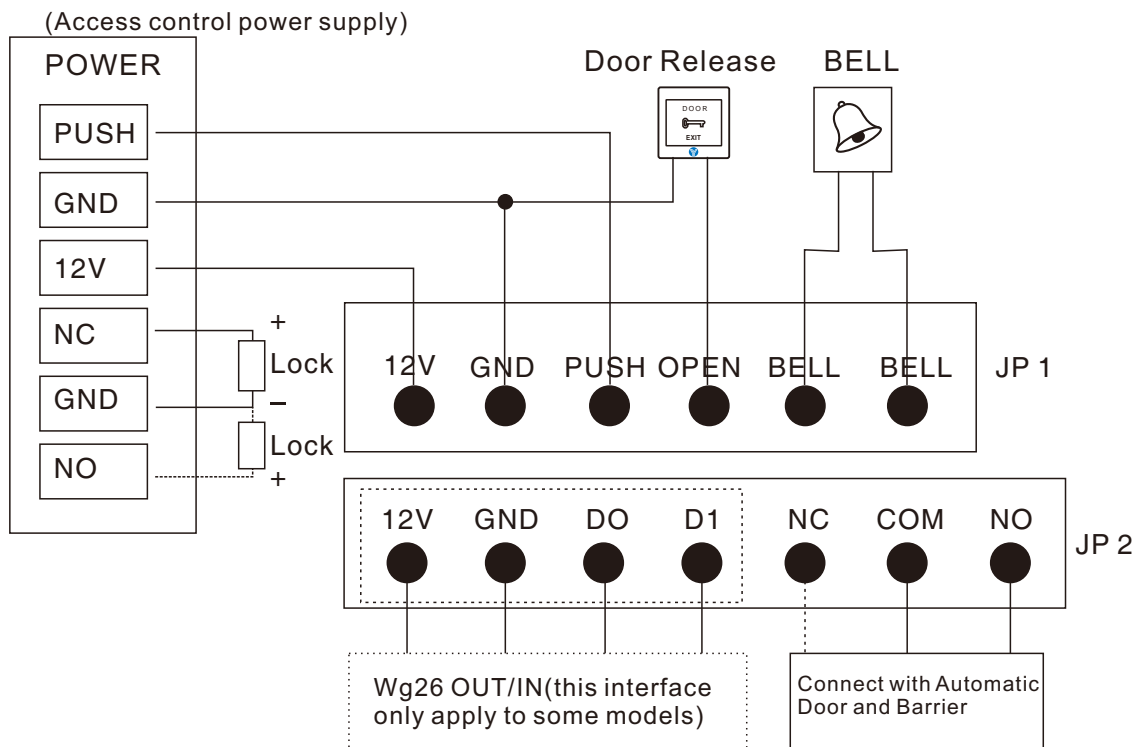

ACCESS CONTROL FUNCTION SETTING

Programming Operating Instruction: (The programming Code Factory Defaults: 123456)

	NAME	Continual Key-Press (Read Card) Operating	NOTE
Common operation	Modify programming Password	#programming Password#0 New programming Password #Repeat the New programming Password#	LOST PASSWORD: according to the initial programming operation
	Add User	#programming Password#1 Read Card#	Continual Read Card can add multiple Cards at one-time
	Add (Modify) Public Access password	#programming Password#21 New Password#	Only can set one set of Public Access password: use password to access, input "password", then press #
	Delete All User Delete User (Read Card)	#Programming Password#400000 #Programming Password#410000	This operation will delete all users, but will not delete Public Access Password. Continual Read Card can delete multiple Cards at one-time

Extended operation	Add personal Access Password	#Programming Password#22NEW password#	Can set up multiple sets of personal password: Accessed by Password, input password then press#
	Add User Card(input Card Number)	#Programming Password#23#Manual input initial card number	The Card Number can be the 10 digits in the blank space on the left side of the Card or the 8 digits on the right side of the card, the machine identify automatic
	Add User Card(Continual Card Number)	#Programming Password#23#Manual input initial card number Card Quantity#	The Card quantity must be 4 digits(input 0020 can add 20 cards at one-time)
	Add "Card+Password" User	#Programming Password#3Read Card NEW password#	Modify the corresponding password, please refer to the instruction of modifying corresponding personal Access password
	Delete User(input ID No.)	#Programming Password#42 User ID	The User ID must be 4 digits, for example 0001, 0020, etc. Details shown in User ID Instruction
	Delete User(input Card No.)	#Programming Password#43 Manual input card number	The Card Number can be the 10 digits in the blank space on the left side of the Card or the 8 digits on the right side of the card, the machine identify automatic
	Delete User(input password)	#Programming Password#44 Personal Access password#	Delete the corresponding User of this card, and the corresponding Card number of this password will be delete as well
	Delete all Password User	#Programming Password#45 1111#	All the User that only accessed by personal Password will be delete
	Modify Relay unlocking time	#Programming Password# 5 x x#	"xx" is 2 digits, Up to 99 seconds, if input 00, the Relay signal Instantaneous output(0.2sec)
	Set the open mode	#Programming Password# 6 x x #	"xx" can be 01(Read Card); 02(Read Card or Password); or 03(Card+Password)
	Card reader function	#Programming Password#604#	Read card under this Mode, WG Interface will output WG26 Signal, this product can be used as Card reader(only apply to some models)
	Set Security Function	#Programming Password#7xx#	"xx" can be 01 or 02(Security feature Close/Open)/03 or 04(Tamper alarm Close/Open)(only apply to some models)
	Set Backlight Mode	#Programming Password#8xx#	xx" can be 01(Light NC)/02(light NO)/03(Auto)(only apply to some models)
	Reset machine factory Settings	#Programming Password#899#	All machine parameters will be restore to Factory default

INITIALIZE THE PROGRAMMING CODE(123456)AND the Card SETTING MANAGEMENT

Step 1: Power off ,the RST(SI) wire jumper hat connect to 2/3 interface ,re-up electricity , 3 long buzz then the Green Light fast flash,the programming code restore to Factory default

Step 2:(If No need to manage Cards,This step can be omitted):Continual to read two blank Cards(the first one is Added Card,the second one is deleted card),Red light flash, continuous short buzz.

Step 3:Power off,wire jumper reconnect 1/2,re-up electricity,initialize programming code and managed card Adding finished

THE USE OF MANAGED CARD

Add User Card : In the standby status,read added Card,then read the user Card want to add at the end ,read added Card to log out .

Delete User Card: In the standby status,read deleted Card,then read the user card want to delete,at the end read deleted Card to log out .

Delete all Users:In the standby status,read deleted Card,then read the added card,at the end to read deleted Card to log out .This operation will delete all users,include personal password user(not include public password)

USER NO. INTRODUCTIONS

The machine default user ID is contained by 4 digits(for example,0001),add a user each time ,the user number will add 1 automatic,when remove a single user,this number will be emptied,will not influence the serial number of new added user(the new added user number will be the last added user number +1),after execute the delete all user command(the programming command 40 or use Managed Card),the user number will re-start from 0001.Public access password doesn't occupy the User Serial Number.

MODIFY THE CORRESPONDING PERSONAL ACCESS PASSWORD OF CARD

Set the open mode as "Card+ Password",user read card then input password and press"#",open successfully within 5 sec,long press "#" until the green light fast flash,meanwhile,input new password # repeat new password #,1 long buzz,the corresponding personal Access password of this card is modified successfully.