



DIESEL GENERATING SETS
INSTALLATION RECOMMENDATIONS
AND OPERATIONS MANUAL

1. INTRODUCTION.....	1
1.1. Receipt Of The Genset.....	1
1.2. Diesel Genset And Its Equipments.....	2
1.3. Installation That Should Be Done By Customer.....	2
1.4. Personnel Classification, Who Will Do Maintenance, Adjustments and Repair.....	2
1.5. Environmental Protection.....	3
1.6. Using Gensets Efficiently.....	3
2. GENERAL SAFETY PRECAUTIONS.....	3
2.1. General.....	3
2.2. Installation Handling And Towing.....	4
2.3. Fire And Explosion.....	4
2.4. Mechanical.....	4
2.5. Chemical.....	5
2.6. Noise.....	5
2.7. Electrical.....	5
2.8. First Aid For Electric Shock.....	6
3. GENERAL DESCRIPTION.....	6
3.1. Generator Set Description And Identification.....	6
3.2. Generator Set Main Parts.....	7
3.3. Diesel Engine.....	7
3.4. Engine Electrical System.....	8
3.5. Cooling System.....	8
3.6. Synchronous Alternator.....	8
3.7. Coupling.....	8
3.8. Fuel Tank And Base Frame.....	8
3.9. Vibration Isolation.....	8
3.10. Silencer And Exhaust System.....	8
3.11. Control System.....	8
4. ELECTRIC STARTING SYSTEM.....	8
4.1. Battery Systems.....	8
4.2. Maintenance Batteries.....	9
4.3. Maintenance Free Batteries.....	10
4.4. Starting Aids.....	10
5. HEALTHY AND SAFETY.....	10
5.1. Fire Protection.....	10
5.2. Exhaust Gases.....	11
5.3. Moving Parts.....	11
5.4. Hazardous Voltages.....	11
5.5. Water.....	11
5.6. Coolant And Fuel.....	12

5.6. Coolant And Fuel.....	12
6. GENERATING SET CONTROL SYSTEM.....	12
6.1. Control System P732.....	12
6.2. Control System P602.....	13
6.3. Icons And LCD Identification.....	15
6.4. Battery Charger.....	16
6.5. Control System Options.....	16
6.6. Heaters.....	16
6.7. Electric Fuel Transfer Pump.....	16
6.8. Voltage / Frequency Adjustment.....	16
7. USE REQUIREMENTS.....	16
7.1. General Precautions And Controls Which Must Be Done Before Starting Up The Generating Set.....	16
7.2. General Precautions And Controls Which Must Be Done After Starting Up The Generating Set.....	16
8. LUBRICATING OIL.....	17
8.1. Oil Performance Properties.....	17
8.2. Lubrication Oil Recommendation For Ricardo.....	17
9. GENERATOR SET MAINTENANCE.....	19
9.1. Maintenance Schedule For Gensets.....	19
9.2. Maintenance Interval Chart.....	19
10. ENGINE TROUBLESHOOTING.....	20
11. ALTERNATOR DESCRIPTION.....	22
11.1. General.....	22
11.2. Construction And Components.....	22
11.3. Operation.....	22
11.4. Automatic Voltage Regulator.....	22
11.5. Alternator Insulation Test.....	22
11.6. Meccalte Alternator Troubleshooting.....	23
12. STORAGE.....	23
12.1. Engine Storage.....	23
12.2. Alternator Storage.....	25
12.3. Battery Storage.....	25
13. WARRANTY.....	25
14. GENERAL PRECAUTIONS.....	25
15. CUSTOMER RESPONSIBILITY.....	26

as both the operator and the mechanical technician. In addition, the electrical technician may carry out electrical repairs within the various enclosures of the unit.

This includes work on live electrical components.

Skill level 4: Specialist from the manufacturer

This is skilled specialist sent by the manufacturer or its agent to perform complex repairs or modifications to the equipment.

In general it is recommended that not more than two people operate the unit, more operators could lead to unsafe operating conditions. Take necessary steps to keep unauthorized person away from the unit and eliminate all possible source of danger at the unit. The manufacturer does not accept any liability for any damage arising from the use of non-original parts and for modifications, additions or conversions made without the manufacturer's approval in writing.

1.5. Environmental Protection

Choose the Gensets installation location very carefully in order to not disturb anyone, and not to cause noise pollution. If the location is not appropriate, the Gensets rooms have to be insulated for noise reduction and also critical type exhaust silencer could be used if necessary. Engine oil should be collected in a tank, not to be drained to drainage or floor. Learn how the oils are collected from oil supplier and deliver it to those companies. Prevent oil and fuel from contaminating environment,

If the Gensets will be located in a wood or coppice, necessary precautions have to be taken against fire.

Around of the Gensets should be cleaned carefully.

Expired and damaged batteries should be sent back to the battery supplier. Batteries could be recycled, so that poisonous waste, acid and lead are prevented from polluting the environment.

1.6. Using Gensets efficiently;

To ensure the efficient fuel consumption;

- Ventilation of the Gensets have to be done as described in this Manual.
- Maintenance of the Gensets should be done in time.
- Do not over load the Gensets, it will decrease engine life.
- Worn parts (pistons, piston rings, bearings, liners

etc.) should be replaced

- Injectors should be clean and adjusted.
- Air filter should be clean
- Engine valve adjustment should be done in time.
- Do not load the engine less than 30% of prime power, it will increase the fuel consumption, oil consumption and damage the engine.

If above instructions are followed, Gensets fuel consumption efficiency will be increased.

2. GENERAL SAFETY PRECAUTIONS

2.1. General

The generator set is designed to be safe when used in correct manner. However responsibility for safety rests with the personnel who install, use and maintain the set. If the following safety precautions are followed, the possibility of accidents will be minimized. Before performing any procedure or operating technique, it is up to the user to ensure that it is safe. The generator set should only be operated by personnel who are authorized and trained.

WARNING

! Read and understand all safety precautions and warnings before operating or performing maintenance on the generating set.

! Failure to follow the instructions, procedures, and safety precautions in this manual may increase the possibility of accidents and injuries.

! Do not attempt to operate the generating set with a known unsafe condition.

! If the generating set is unsafe, put danger notices and disconnect the battery negative (-) lead so that it cannot be started until the condition is corrected.

! Disconnect the battery negative (-) lead prior to attempting any repairs or cleaning inside the enclosure.

! Install and operate this generating set only in full compliance with relevant National, Local or Federal

2.2. Handling and Towing

The following safety precautions should be noted:

WARNING

! Make electrical connections in compliance with relevant Electrical Codes, Standards or other requirements. This includes requirements for grounding and ground/earth faults.



! For stationary generating sets with remote fuel storage systems, make sure such systems are installed in compliance with relevant Codes, Standards or other requirements.

! Engine exhaust emissions are hazardous to personnel.

The engine exhaust for all indoor generating sets must be piped outdoors via leak-free piping in compliance with relevant Codes, Standards and other requirements. Ensure that hot exhaust silencers and piping are clear of combustible material and are guarded for personnel protection per safety requirements. Ensure that fumes from the exhaust outlet will not be a hazard.

! Never lift the generating set by attaching to the engine or alternator lifting lugs, instead use the lifting points on the base frame or canopy.

! Ensure that the lifting rigging and supporting structure is in good condition and has a capacity suitable for the load.

! Keep all personnel away from the generating set when it is suspended.

! When mobile generating set, observe all Codes, Standards or other regulations and traffic laws. These include those regulations specifying required equipment and maximum and minimum speeds.

! Do not permit to ride on the mobile generating set.

Do not permit personnel to stand or ride on the drawbar or to stand or walk between the generating set and towing vehicle,

! Do not install and operate a GenSet in an area that is classified as dangerous, if necessary precautions are not taken

! Please follow the instruction written in the 'Diesel Gen-Set Installation Recommendation Manuel,

2.3. Fire and Explosion

Fuel and fumes associated with generating sets can be flammable and potentially explosive. Proper care in handling these materials can dramatically limit the risk of fire or explosion. However, safety dictates that fully charged BC and ABC fire extinguishers are kept on hand.



Personnel must know how to operate them.

WARNING

! Ensure that the generating set room is properly ventilated.

! Keep the room, the floor and the generating set clean.

When spills of fuel, oil, battery electrolyte or coolant occur, they should be cleaned up immediately.

! Never store flammable liquids near the engine.

! Do not smoke or allow sparks, flames or other sources of ignition around fuel or batteries. Fuel vapors are explosive. Hydrogen gas generated by charging batteries is also explosive.

! Turn off or disconnect the power to the battery charger before making or breaking connections with the battery.

! To avoid arcing keep grounded conductive objects (such as tools) away from exposed live electrical parts (such as terminals). Sparks and arcing might ignite fuel or vapors.

! Avoid refilling the fuel tank while the engine is running.

! Do not attempt to operate the generator set with any known leaks in the fuel system.

! There has to be an emergency exit for the staff in the case of fire.

2.4. Mechanical

The generating set is designed with guards for protection from moving parts. Care must still be taken to protect personnel and equipment from other mechanical hazards when working around the generating set.

WARNING

! Do not attempt to operate the generating set with the safety guards removed. While the generating set is running do not attempt



to reach under or around the guards to do maintenance or for any other reason.

! Keep hands, arms, long hair, loose clothing and jewelers away from pulleys, belts and other moving parts.

Attention: Some moving parts cannot be seen clearly when the set is running.

! If equipped keep access doors on enclosures closed and locked when not required to be open.

! Avoid contact with hot oil, hot coolant, hot exhaust gases, hot surfaces and sharp edges and corners.

! Wear protective clothing including gloves and hat when working around the generating set.

! Do not remove the radiator filler cap until the coolant has cooled. Then loosen the cap slowly to relieve any excess pressure before removing the cap completely.



2.5. Chemical

Fuels, oils, coolants, lubricants and battery electrolyte used in this generating set are typical of the industry. However, they can be hazardous to personnel if not treated properly.

WARNING

! Do not swallow or allow skin contact with fuel, oil, coolant, lubricants or battery electrolyte. If swallowed, seek medical treatment immediately.

Do not induce vomiting if fuel is swallowed. For skin contact, wash with soap and water.

! Do not wear clothing that has been contaminated by fuel or lube oil.

! Wear an acid resistant apron and face shield or goggles when servicing the battery. If electrolyte is spilled on skin or clothing, flush immediately with large quantities of water.



2.6. Noise

Generating sets that are not equipped with sound attenuating enclosures can produce noise levels in excess of 105 dB(A). Prolonged exposure to noise levels above 85 dB(A) is hazardous to



hearing.

WARNING

Ear protection must be worn when operating or working around an operating generating set.

2.7. Electrical

Safe and efficient operation of electrical equipment can be achieved only if the equipments is correctly installed, operated and maintained.



WARNING

! The generating set must be connected to the load only by trained and qualified electricians who are authorized to do so, and in compliance with relevant Electrical Codes, Standards and other regulations.

! Ensure that the generating set, including a mobile set is effectively grounded/ earthed in accordance with all relevant regulations prior to operation.

! The generating set should be shutdown with the battery negative (-) terminal disconnected prior to attempting to connect or disconnect load connections.

! Do not attempt to connect or disconnect load connections while standing in water or on wet or soggy ground.

! Do not touch electrically energized parts of the generating set and/or interconnecting cables or conductors with any part of the body or with any non insulated conductive object.

! Replace the generating set terminal box cover as soon as connection or disconnection of the load cables is complete. Do not operate the generating set without the cover securely in place.

! Connect the generating set only to loads and/ or electrical systems that are compatible with its electrical characteristics and that are within its rated capacity.

! Keep all electrical equipment clean and dry. Replace any wiring where the insulation is cracked, cut, abraded or otherwise degraded. Replace terminals that are worn, discolored or corroded. Keep terminals clean and tight.

! Insulate all connections and disconnected wires.

! Use only Class BC or Class ABC extinguishers on electrical fires.

2.8. First Aid for Electric Shock

WARNING

! Do not touch the victim's skin with bare hands until the source of electricity has been turned off.

! Switch off power if possible otherwise pull the plug or the cable away from the victim.

! If this is not possible, stand on dry insulating material and pull the victim clear of the conductor, preferably using insulated material such as dry wood.

! If victim is breathing, turn the victim clear of the conductor, preferably using insulated material such as dry wood.

! If victim is breathing, turn the victim into the recovery position described below. If victim is unconscious, perform resuscitation as required;

Open the airway

Tilt the victim's head back and lift the chin upwards.

Remove objects from the mouth or throat (including false teeth, tobacco or chewing gum).



Breathing

Check that the victim is breathing by looking, listening and feeling for the breath.



Circulation

Check for pulse in the victim's neck.

If no breathing but pulse is present

- Pinch the victim's nose firmly.
- Take a deep breath and seal your lips around the victim's lips.
- Blow slowly into the mouth watching for the chest to rise. Let the chest fall completely. Give breaths at a rate of 10 per minute.
- If the victim must be left to get help, give 10 breaths first and then return quickly and continue.
- Check for pulse after every 10 breaths.
- When breathing restarts, place the victim into the recovery position described later in this section.



If no breathing and no pulse

- Call or telephone for medical help.
- Give two breaths and start chest compression as follows:
 - Place heel of hand 2 fingers breadth above ribcage/breastbone junction.
 - Place other hand on top and interlock fingers.
 - Keeping arms straight, press down 4-5 cm at a rate of 15 times per minute.
 - Repeat cycle (2 breaths and 15 compressions) until medical help takes over.
 - If condition improves, confirm pulse and continue with breaths. Check for pulse after every 10 breaths.
 - When breathing restarts, place the victim into the recovery position described below.



Recovery position

- Turn the victim onto the side.
- Keep the head tilted with the jaw forward to maintain the open airway.
- Make sure the victim cannot roll forwards or backwards.
- Check for breathing and pulse regularly. If either stops, proceed as above.



WARNING

! Do not give liquids until victim is conscious.

3. GENERAL DESCRIPTION

3.1. Generator Set Description and Identification;

Diesel generator sets are independent units for the production of electric power; basically, they comprise a constant voltage synchronous generator driven by an internal –combustion, diesel – four cycle engine.

The sets are used for two main purposes:

a- Continuous duty sets

Used to produce electric power for countless requirements (motive power, lighting, heating, etc) in areas where other sources or power are unavailable.

b- Emergency duty sets

Used during public network failures, when such failures

are liable to cause serious trouble to persons or material or financial damage (i.e. in hospitals, industrial plants with non-stop operating cycles, etc) or to meet peak energy demands.

According to their application, the sets are further divided into:

- Set for use on land.
- Set for use at sea.

The sets for use on land can be either:

- Stationary sets (fixed installation), or
- Mobile sets (mobile installation)

These two types of sets are available in a vast range of versions, for every operating requirement, the main ones being:

01. Hand control generating sets
02. Stand-by generating sets

The standard stationary generating set comprises:

- Diesel engine.
- Synchronous generator.
- Coupling.
- Radiator.
- Metal sub-base with vibration isolators.
- Starter batteries.
- Fuel tank within the baseframe.
- External fuel tank (for high power generators).
- Instrument panel.
- Exhaust gas silencer.

ARMAK Generator Set has been designed as a complete package to provide superior performance and reliability.

Figure 3.1. Identifies the major components. This figure is of a typical generating set. However, every set will be slightly different due to the size and configuration of the major components. This section briefly describes the parts of the generating set. Further information is provided in later sections of this manual.

ARMAK generating sets are an Alternating Current generator, built for continuous running at sites where no electricity is available (some models are excepted) or as stand-by in case of interruption of the mains. The generator operates at 230/220 V in line-to-neutral mode and 400/440 V in line-to-line mode. at 50 Hz ,

120V/208, 220/380, 277/480 at 60 Hz. Some diesel engines couldn't be used as 60 Hz.

3.2. Generating Set Main Parts

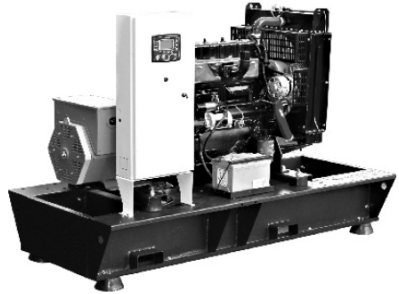

Figure 3.1. Typical generator set configuration

No Description

1. Generator set rating label.
2. Diesel engine.
3. Air filter.
4. Radiator.
5. Alternator.
6. Terminal box.
7. Base frame.
8. Control Panel.

3.3. Diesel Engine

The diesel engine powering the generator set (Item 2) has been chosen for its reliability and the fact that it has been specifically designed for powering generator sets. The engine is of the heavy duty industrial type with 4 stroke compression ignition and is fitted with all accessories to provide a reliable power supply. These accessories include, among others, a cartridge type dry air filter (item 3) and a mechanical or an electronic engine speed governor.

The engine cylinder block is cast in one piece cast iron, vertical cylinders inline overhead valves and camshaft in block. The cylinder heat is made of special cast iron. The thermally loaded flame plate is efficiently water cooled. The crankshaft is forged in one piece in high tensile steel.

Lubrication: forced lubrication via gear pump, special Spin-on filters, lubricant cooling via heat exchanger.

3.4. Engine Electrical System

The engine electrical system is 12 volt or 24 volts DC, negative ground/earth. This system includes an electric engine starter, a battery and a battery charging alternator. For 12 volts electrical system one battery is given. For 24 volt system two lead-acid batteries are given. Other types of batteries may be fitted if they were specified. Batteries are detailed in Section 4.

3.5. Cooling System

The engine cooling system is water cooled. The water cooled system is comprised of a radiator (item 4) a pusher fan and thermostat. The alternator has its own internal fan to cool the alternator components.

3.6. Synchronous Alternator

Horizontal axle alternator (synchronous three phase), on rolling bearings, self-ventilated within the room with low-loss silicon-sheet stator bundle, electrolytic copper winding with class H insulation.

Case –type damper winding for parallel operation (on high-powered alternators).

The output electrical power is normally produced by IP23 and a screen protected and drip-proof, self-exciting, self regulating, brushless alternator. (Item 5) Fine tuned to the output of this generating set.

Mounted on top of the alternator is a sheet steel terminal box (item 6)

3.7. Coupling

If Single bearing alternators are used, a special flexible disk is used in place of a flexible coupling. If two bearing alternator is used, Engine and alternator are firmly joined by a coupling cone that guarantees the proper assembly coaxiality.

3.8. Fuel tank and Base frame

The engine and alternator are coupled together and mounted on a heavy duty steel base-frame (Item 7). This base frame includes a fuel tank with capacity of approximately 8 hours operation under variable loads. The tank is complete with filling cap and fuel level gauge and is connected by flexible joints to the intake piping and to the overflow piping containing fuel from the injector drain. High power Gensets (above 1100 kVA) fuel tank is separate from set.

3.9. Vibration Isolation

The generator set is fitted with vibration isolators which are designed to reduce engine vibration being transmitted to the foundation on which the generator set is mounted. These isolators are fitted between the engine /alternator feet and the base frame.

3.10. Silencer and Exhaust system

An exhaust silencer is provided loose for installation with the generating set (for open sets). The silencer and exhaust system reduce the noise emission from the engine and can direct exhaust system reduce the noise emission from engine and can direct exhaust gases to safe outlets.

3.11. Control System

One of several types of control systems and panels (item 8) may be fitted to control the operation and output of the set and to protect the set from possible malfunctions. Section 6 of this manual provides detailed information on these systems and will aid in identification of the control system fitted on the generator set.

4. ELECTRIC STARTING SYSTEMS

Electric starting systems are generally used on all gensets. Electrical starting system consists of a starter, mounting flange to the flywheel and bendix gear. There could be 2 starters on big engines.

The power source for electric starting systems is a 12V or 24V DC battery system. The starting voltage is determined by engine size, 24 VDC being used for larger engines to reduce starting current and hence cable size. Control of starting is via a start solenoid which is controlled by the gen-set control system.

4.1. Battery Systems

Batteries are of two types– lead acid and NiCad. Lead acid batteries are generally used, being the least expensive.

NiCad batteries are used where longer life, etc., is required.

Batteries are one of the main parts of the Gensets, and it could be said that 90% of the Gensets fault is caused by battery. So it is important to do regular maintenance and checks on batteries. Batteries are mounted on

the base frames in most of TMGPOWER Gensets.

Battery charging systems;

While the Genset is running, batteries are charged by charging alternator.

If the Genset is not running, batteries are charged by battery chargers that powered by mains.

4.2. Maintenance Batteries

Warning

- Do not smoke or allow sparks, flames or other sources of ignition around batteries. Hydrogen gas generated by charging batteries is explosive.
- Wear an acid resistant apron and face shield or goggles when servicing the battery. If electrolyte is spilled on skin or clothing, flush immediately with large quantities of water.
- Take out the metallic things in your wrist and protect your wrist and hand.
- Disconnect the battery negative (earth) lead first and reconnect last.
- Always ensure that battery maintenance is carried out in a well ventilated area.
- The starting batteries should be located as close as possible to the generator set while still being accessible for servicing. This will prevent electrical losses.

Adding the first electrolyte in to battery

1. Take out the protective cover above the battery, and vent caps.

2. Add electrolyte to the Battery up to 15mm above the plates. Electrolyte specific gravity should be 1,28 at 20 °C. Battery and electrolyte temperature should be more than 10 °C.
3. Wait 15 minutes. the heat will increase between the plates and bobble will occur above the electrolyte.
4. Fix the vent caps.
5. Check the battery with hydrometer after 15 minutes.
6. Minimum charging time is 6 hours. Check the charging amps and electrolyte level every one hour. if there is no changing within one hour, it is charged.
7. When the battery is charged, check the electrolyte level after 2 hour, if the level is decreased add water up to 10 mm above the plates.

Battery Maintenance

- Keep the top of the battery and its terminals clean.
- Cover the battery terminals and its connections with Vaseline.
- Tighten the terminals but not tighten it hardly.
- Control the electrolyte level periodically. It must be 10 mm above the plates.
- Control the abrasion in the charge alternator belt and check periodically the belt tension according to producer' recommendation.
- Ensure that your battery is not uncharged.(please see the below table).

State of Charge	Specific Gravity	Voltage - 12V
100%	1.265	12.7
75%	1.225	12.4
50%	1.190	12.2
25%	1.155	12.0
Discharged	1.120	11.90

Table 4. 2.1. Typical generator set configuration

Testing the battery

- Inspect the battery before the test.
- Battery terminals and connections will be corroded in time. Corrosion will wear the terminals and prevent charging. Disconnect the battery terminals and clean the oxidation with hot water and then reconnect the terminals and coat them with Vaseline.
- Don't allow loose connection.

Hydrometer test

Battery charge situation and the specific gravity of the sulfuric acid could be measured by hydrometer.

1. Don't use distilled water only use pure water.
2. Insert the hydrometer into electrolyte, hydrometer should stay vertically, Once the hydrometer comes to a rest, observe the plane of the liquid surface. Your eye must be horizontal to this plane
Evaluation is mentioned below;

1,2701,280 fully charged

1,2201,230 50% charged

1,1501,220 discharged

4.3. Maintenance Free Batteries

Ensure that all battery connections are correct and batteries are always charged. After that there is not any procedure for this battery.

Control of the Battery;

Conduct an inspection every time before testing the battery.

1. A white powdered element causes abrasion to the pole-heads, its connections. Remove the connections and wash them with hot water to purify the oxidation. Reconnect it and coat with Vaseline.
2. Check if any un-tightened connections exist.

4.4. Starting Aids

It is customary to maintain coolant temperatures above 40°C min. To promote quick starting on an emergency generator set and to take the load. Thermostatically controlled external block heaters, deriving their supply from the primary source of power are fitted in the engine cooling system to provide this heating. Heater warms up the jacket water of the engine when

the generator set is not working.

5. HEALTHY and SAFETY

Safety should be the primary concern of the facility design engineer and all personnel engaged on installation and commissioning. Safety involves two aspects:

- 1) Safe operation of the generator itself (and its accessories).
- 2) Reliable operation of the system.

Reliable operation of the system is related to safety because equipment affecting life and health, such as life support equipment in hospitals, emergency egress lighting, building ventilators, elevators and fire pumps, may depend on the generator set.

5.1. Fire Protection

Diesel Fuel can be stored on the floor in an appropriate tank .Although the flammability of the diesel is high , it can still catch fire , so that fire extinguishers have to be provided in the storage. Foam or CO2 have to be used for diesel , oil , gas etc.

For electrical cables and bus bar contactors use CO2 or CTC.

Sand could be used for Isolations and small fires.

The design, selection and installation of fire protection systems require the following considerations:

- The fire protection system must comply with the requirements of National Standards.
- Typically, the generator room will be required to have one hour fire resistance rating. Generator room construction will have to have two hour fire resistance rating.
- Generator room shall not be used for storage purposes.
- The authority may specify the quantity, type and sizes of approved portable fire extinguishers required for the generator room.
- A manual emergency stop station outside the generator room or enclosure or remote from the generator set in an outside enclosure would facilitate shutting down the generator set in the event of a fire or another type of emergency.
- Generator sets have to be run at full load at least once a year to prevent the accumulation of diesel in exhaust system.

General

- Do not fill fuel tanks when the engine is running, unless tanks are located outside the generator room.
- Do not permit any flame, cigarette, pilot light, spark, arcing equipment, or other ignition source near the generating set or fuel tank.
- Fuel lines must be adequately secured and free of leaks. Fuel connection at the engine should be made with an approved flexible line. Do not use copper piping on flexible lines as copper will become brittle if continuously vibrated or repeatedly bent.
- Be sure all fuel supplies have a positive shut-off.

5.2. Exhaust Gases

- Be sure the exhaust system will properly dispel discharged gases a way from enclosed or sheltered areas and areas where individuals are likely to congregate.
- Never connect the exhaust system of two or more engines.
- Never discharge engine exhaust into a brick, tile or cement block chimney, or a similar structure. Exhaust pulsations could cause severe structural damage.
- Do not use exhaust gases to heat a compartment.
- Be sure that the unit is well ventilated.
- Ensure that there is independent support for the exhaust system. No strain should be imposed on the engine exhaust manifolds. Which is especially important on a turbocharged engine.
- Exhaust pipes should be logged or protected to prevent touching or causing fire.

5.3. Moving Parts

- Tighten supports and keep guards in position over fans drive belts etc. Make sure that fasteners on the set are secure.
- Keep hands, clothing and jewellery away from moving parts.
- If adjustment must be made while the unit is running, use extreme caution around hot manifolds, moving parts, etc.

5.4. Hazardous Voltages

Improper wiring can cause fire or electrocution, resulting in severe personal injury or death and property or equipment damage.

For personal protection, stand on a dry wooden platform or rubber insulating mat, make sure clothing and

shoes are dry, remove jewellery from hands and use tools with insulated handles.

- Do not leave cables trailing on the engine room floor.
- Do not use the same trunk line for electric cables and fuel water lines.
- Do not run AC and DC cables in the same looms or trunk line.
- Always ensure that bonding and equipment earthing are correctly done. All metallic parts that could become energized under abnormal conditions must be properly earthed.
- Always disconnect the batteries and battery charger when serving or carrying out maintenance particularly on equipment arranged for automatic mains failure operation. Always disconnect a battery charger from its AC source before disconnecting the battery cable. Accidental starting of the generator set while working on it can cause severe personal injury or death.
- Do not tamper with interlocks.
- Electrical connections and installation should be done by persons trained and qualified
- Do not connect the generator set directly to any building electrical system.
- Always follow all applicable state and local electrical codes.
- High voltage sets work differently to low voltage ones. Special equipment and training is required to work around high voltage equipment. Operation and maintenance must be done only by persons trained and qualified to work on such devices. Improper use or procedures may well result in personal injury or death.
- Do not work on energised equipment. Unauthorised personnel must not be permitted near energised equipment. Due to the nature of high voltage electrical equipment includes voltage remains after the equipment is disconnected from the power source. Equipment should be de-energised and safety earthed.

5.5. Water

Water or moisture inside a generator increases the possibility of "flashing" and electrical shock, which can cause equipment damage and severe personal injury or death. Do not use a generator which is not dry inside and out.

5.6. Coolant and Fuel

The coolant heater must not be operated while the cooling system is empty or when the engine is running or damage to the heater will occur.

Coolant under pressure have a higher boiling point than water.

- Do not open a radiator, heat exchanger or header tank pressure cap while the engine is running. Allow the generator set to cool and bleed the system pressure first.
- Never use galvanised or copper fuel lines, fittings or fuel tanks. Condensation in the tanks and lines combines with the sulphur in the fuel to produce sulphuric acid. The molecular structure of the copper or galvanised lines or tanks reacts with the acid and contaminates the fuel.

BUTTON	FUNCTION
	Selects TEST mode. The genset runs and takes the load.
	Selects RUN mode. The genset runs off-load.
	Selects AUTO mode. The genset runs when necessary and takes the load.
	Selects OFF mode. The genset stops.
	Selects next display screen in the same display group. LAMP TEST when held pressed.
	Selects previous display group.
	Selects next display group.
	Selects previous display screen in the same display group. Resets the ALARM RELAY.
	When held pressed for 5 seconds, enters PROGRAMMING mode.
	Makes factory reset. Please review chapter RESETTING TO FACTORY DEGAULTS for more details.
	When held pressed for 5 seconds, resets service request counters. Please review chapter SERVICE REQUEST ALARM for more details.

9.6. LED LAMPS



9.1. FRONT PANEL FUNCTIONALITY

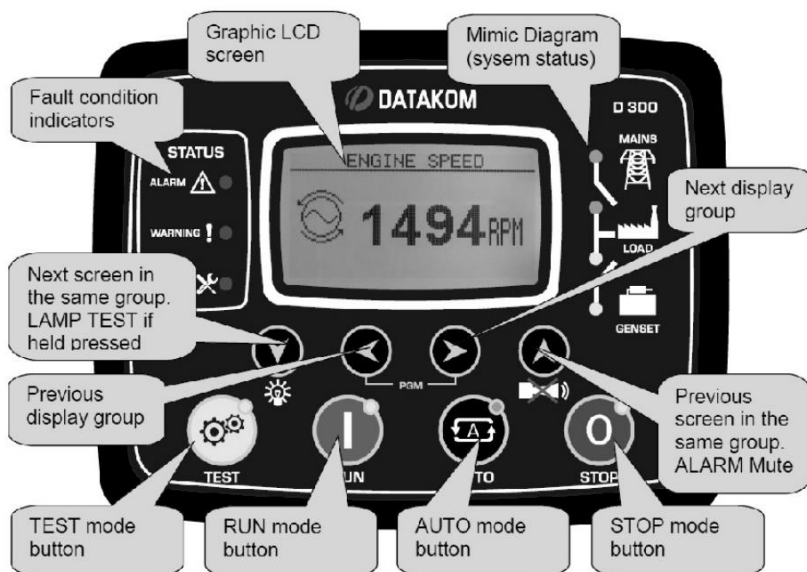

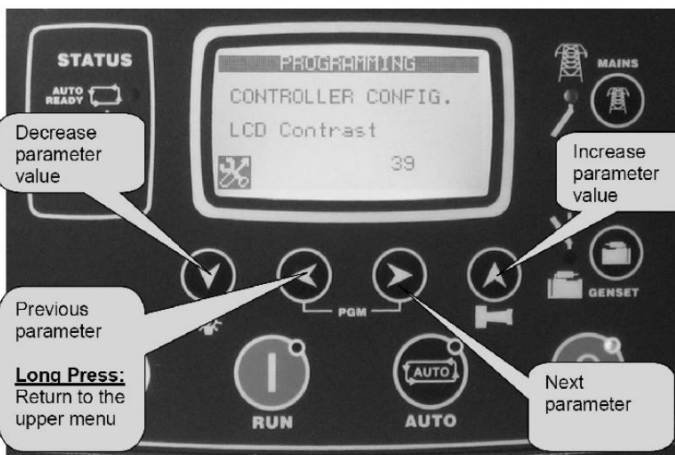
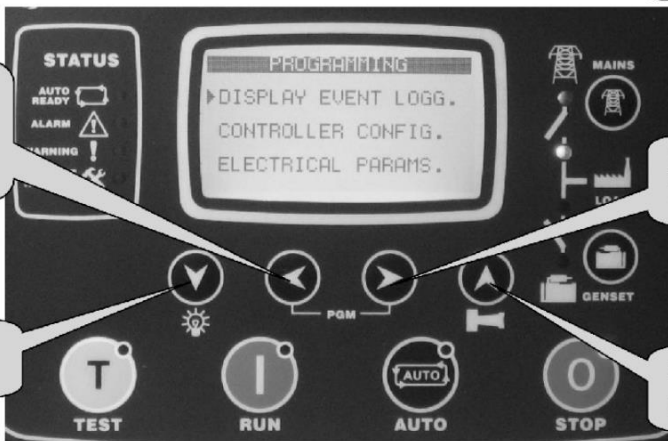

6.4. Battery charger

When the Gensets are not running for a long time , battery charger is used in order to charge the battery ,Battery charger is powered by mains , and mounted in the control panel. A battery charger ampere indicator can be added to control pane in order to see whether battery charger is working or not .

6.5. Control System Options

According to customer request, different options could be added to control system.

- Parallel with mains continuously and black start system with mains.
- Automatic synchronizing and power control system (Multi Gensets parallel).
- Load sharing system (scada).
- Remote monitoring and control.
- Remote alarm panel.
- Backup generator system.

6.6. Heaters

Alternator heaters could be mounted on the alternator stators to keep it dry and protect it from humidity and a heater could be mounted in the control panel to prevent it against humidity too.

6.7. Electric Fuel Transfer Pump

Electric Fuel Transfer Pump could be necessary to pump the fuel from main tank to daily tank .Pump control circuit is mounted in the control panel.

6.8. Voltage / Frequency Adjustment

A potentiometer could be mounted in the control panel to adjust the frequency or voltage or both of them. Frequency adjustment potentiometer is connected the electronic governor control module.

7. USE REQUIREMENTS

7.1. General Precautions And Controls Which Must Be Done Before Starting Up The Generating Set

- Make a general visual inspection on the engine and alternator. Check if there is any breakage, crack, indentation, leakage or looseness. Never operate the generating set before removing any fault, if any.
- Take out foreign materials such as keys, tools, clea

cleaning

wool, papers etc. on the engine and the alternator.

- Check the fuel level in day tank. Refill with fuel if it is low.
- Check the oil level on the dipstick. Refill with an appropriate oil if it is low. Oil level normally must be close to the maximum level line.
- Look at the water level by opening the radiator tap. If it is inadequate add more water. Water level must be 30 mm lower than the water filling neck.
- Engine cooling water must include antifreeze according to the coolest weather conditions in the area. A mixture of 50% antifreeze and 50% water provides a good protection in all area.
- Inspect the radiator air outlet hood, open if clogged and clear away all obstructions in front of the air outlet.
- Check the air filter gauge. Clean or replace air filter, if necessary.
- Keep the inlet opening open.
- Make sure that the generating set can easily take air from the environment.
- Check the battery connection cables. Take care to tighten the loosened battery terminals with spanner and, cover with special substance and keep clean in order to avoid oxidation.
- Open the battery caps and check the liquid level in the cells for maintenance type battery. Add distilled water, if necessary, so as to be 1 cm higher than the separation. Never fill the cells with tap water, acid water or acid.
- Check if the circuit breaker outlet switch is in OFF position. (For manually operated Genset).
- Make sure that the emergency stop button is not pressed.

7.2. General Precautions And Controls Which Must Be Done After Starting Up The Generating Set

- Check for any abnormal noise or vibration on the generating set.
- Check if the exhaust system has any leakage.
- Monitor the generating set operation by means of the control moduie LCD display. Check the engine temperature and oil pressure Oil pressure must reach the normal value 10 seconds after the generating set operation.
- Monitor the generating set outlet voltage and fre

quency by means of the control module LCD display. Check the voltage, if the voltage between phases is 400 V. and between phase and neutral is 230 V. Voltage is adjusted in the factory , do not try to readjust it.

- Check that the frequency is 51 - 52 Hz on generating sets with mechanical governors and 50Hz on generating sets with electronic governors.
- If an engine block water heater is not available, run the generating set at no-load for 3-5 minutes and when the engine warm than apply on load (for manual models)

Apply load to the generating set as follows on manual mode

- Set the alternator outlet circuit breaker on the panel to ON position.
- Set the load circuit breakers (or fuses) on the distribution panel to ON position one by one. This way, the generating set cannot be suddenly put under full load. Otherwise, the engine stalling or alternator winding insulation of formation or burning can occur.
- Set the alternator outlet circuit breaker on the circuit to OFF position before stop the generating set.
- Continue to run the unloaded engine for purpose of cooling period for 2 minutes and then stop.
- Never operate the generating set before removing any fault, if any.
- Check the oil / coolant/fuel leakage while engine is running.
- Never run the engine below 30%of prime power for a long time.
- Share the load on every phase (U,V,W) equally.
- On automatic controlled gen set load will be on and off automatically.

8. LUBRICATING OIL

Oil system of diesel engine is one of the most important elements of the engine. Correctly made engine overhaul (this subject includes oil change periods, filter change periods, paying attention about selecting the true type of oil) prolongs the life cost of the engine.

8.1. Oil Performance Properties

The American Petroleum Institute (API) the American Society for Testing and Materials (ASTM) and Society

of Automotive Engineers (SAE) has developed and preserved a system in order to classify the lubrication oils for their performance categories

8.2. Lubrication Oil Recommendations for Diesel Engines

Recommends that high quality multi grade SAE 15W/40 high service engine oil in diesel engines are used. At ambient temperatures above -15 °C is 15W40.

The minimum API oil quality levels recommended for use is CH / CI-4, CH or CI-4 can be used in areas where CF4 oil is not yet available, but the oil interval must be reduced API CA, CB, CC, CD, CE, CG4 categories not recommended, do not use.

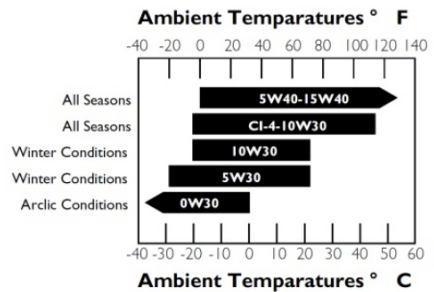

Fig.8.1. Recommended SAE Oil Viscosity Grades v.s. Ambient Temperatures

9. GENERATOR SET MAINTENANCE

A good maintenance program is the key to long generator set life. Maintenance and service should only be carried out by qualified technicians. The maintenance and service which are done must be recorded to the

Maintenance Record Form. In general, the generator set should be kept clean. Do not permit liquids such as fuel or oil film to accumulate on any internal or external surfaces. Wipe down surfaces using an aqueous industrial cleaner.

9.1. Maintenance Schedule for Generator Sets;
Using hour meter as a guide, perform all services at the hourly intervals indicated on following. At each maintenance interval, perform all previous maintenance operations in addition to the ones specified. Keep a record of hourly intervals and services performed.

Important:

Recommended service intervals are for normal operating conditions. Service MORE OFTEN if engine is operated under adverse conditions. Neglecting maintenance can result in failures or permanent damage to the engine.
Use correct fuels, Lubricants and coolant.

9.2. Maintenance Interval Chart

A. Daily or every 20 hours Check

1. Visually inspect engine, generator, transfer switch and control panel.
2. For, Oil, Water and Fuel leaks.
3. For, Coolant level, Oil level, Fuel level.
4. Battery charge level.
5. Operation of coolant heater.
6. Drain Fuel/Water separator.
7. Inspect the engine fan blades.
8. Inspect the drive belt.

B. Weekly Check

Repeat Daily or every 20 hours.

Fuel System;

1. Fuel level in main tank.
2. Day tank float switch.
3. Fuel transfer pump operation.
4. Fuel lines and connections.

Cooling System;

1. Adequate fresh air to engine.
2. Hose and connections.
3. Battery charging alternator belts.
4. Inspect the engine fan blades.
5. Inspect the fan belt.

Exhaust System

1. Exhaust leaks.
2. Tighten connections (if necessary).

Alternator

1. Vent screens.
2. Tighten covers.
3. Output voltage and frequency.

Transfer Switch

1. Operation under load.
2. No unusual sounds.
3. Terminals and connections normal colour.
4. Doors closed securely.

Air System

1. Check leakage
2. Check air filter restriction indicator (if engine has).
Run the Genset for 5-10 minutes on load (if it is possible) or no load.

C. 6 Months or 200 Hours Check

Repeat Weekly

Lubricating System

1. Change, lubricating oil.
2. Change, lubricating oil filters.
3. Clean, crankcase breather.

Fuel System;

1. Change, fuel filters.
2. Drain sediment from main tank.

Cooling System

1. Check, antifreeze.
2. Change, water filter.
3. Lubricate with grease, bearing of the fan hub.
4. Check the fan and connection bolts

Engine safety controls

1. Check operating alarms and safeties.

Other controls

1. Clean the dust and dirt on the Gen. Sets by compressed air.
2. Check the exhaust system's pipes, supports and flexible pipes.
3. Check the mounting bolts of the Genset and AVM's bolt tightness.
4. Check transfer switch ,bus bars ,and connections.
5. Check control panel cable connections.

D. 12 Months or 800 Hours Check

Repeat Maintenance "C"

Fuel System

1. Analyze/replace diesel fuel
2. Check the valves setting and injectors.

Cooling System

1. Clean, exterior of radiators.
2. Replace, radiator's fill cap (over 600 kVA).
3. Check, coolant treatment.
4. Check, anti-freeze solution.
5. Check, water pumps and circulating pumps.
6. Examine duck work.
7. Clean/check motor operated louvers.
8. Clean, engine block water heater.
9. Inspect the engine fan blades.
10. Inspect the fan belt.

Intake System

1. Check air cleaner element and change at 635 mm H2O.

Clean

1. The engine.
2. Generator rotor and stator with compressed air.

Inspect

1. Magnetic pick-up and adjust.
2. Circuit breakers and fuse holders.

Additional to all above check;

1. Measure/record generator winding resistance with Megger.

2. Perform full load test at Nameplate kW.

E. 24 Months or 1000 Hours Check

1. Turbocharger bearing clearance.
 2. Exhaust restriction.
 3. The valves settings.
 4. The injectors settings.
 5. Vibration damper.
 6. Change Coolant and antifreeze and flush system.
 7. Clean Turbocharger compressor wheel and diffuser.
- Additional to all above, do the regular maintenance.

10. ENGINE TROUBLESHOOTING

Possible engine failure and engine failure causes is mentioned below.

The starter motor turns the engine too slowly

- Battery capacity too low.
- Bad electrical connection.
- Faulty in starter motor.
- Wrong grade of lubricating oil.

The engine does not start or difficult to start

- Starter motor turns engine too slowly.
- Fuel tank empty.
- Faulty in fuel control solenoid.
- Restriction in a fuel pipe.
- Faulty in fuel lift pump.
- Dirty fuel filter element.
- Air in fuel system.
- Faulty in injectors or their adjustments.
- Fault in cold start system.
- Restriction in fuel tank vent.
- Wrong type or grade of fuel used.
- Restriction in exhaust pipe.
- Oil pressure sensor / switch or its connection is faulty.
- Oil pressure is too high.
- Wrong grade of lubrication.
- Oil pressure indicator is faulty.

Not enough power

- Restriction in a fuel pipe.
- Faulty in fuel lift pump.
- Dirty fuel filter element.

- Air in fuel system.
- Restriction air filter/cleaner or induction system.
- Restriction in exhaust pipe.
- Fault in injectors or injectors are out of adjustment.
- Restriction in fuel tank vent.
- Wrong type or grade of fuel used.
- Restricted movement of engine speed control.
- Engine temperature is too high or low.

Misfire

- Restriction in a fuel pipe.
- Faulty in fuel lift pump.
- Dirty fuel filter element.
- Air in fuel system.
- Fault in injectors or injectors are out of adjustment.
- Fault in cold start system.
- Engine temperature is too high.
- Incorrect valve tip clearances.
- Oil pressure sensor / switch or its connection is faulty.

The pressure of the lubrication oil is too low

- Wrong grade of lubrication.
- Not enough lubrication oil in sump.
- Defective gauge.
- Dirty lubrication oil filter element.

High fuel consumption

- Restriction air filter/cleaner or induction system.
- Fault in injectors or injectors are out of adjustment.
- Fault in cold start system.
- Wrong type or grade of fuel used.
- Restricted movement of engine speed control.
- Restriction in exhaust pipe.
- Engine temperature is too low.
- Incorrect valve tip clearances.

Black exhaust smoke

- Restriction air filter/cleaner or induction system.
- Fault in injectors or injectors are out of adjustment.
- Fault in cold start system.
- Wrong type or grade of fuel used.
- Restriction in exhaust pipe.
- Engine temperature is too low.
- In correct valve tip clearances.
- Engine over load.

Blue or white exhaust smoke

- Wrong grade of lubrication.
- Fault in cold start system.
- Engine temperature is too low.

The engine knocks

- Faulty in fuel lift pump.
- Fault in injectors or injectors are out of adjustment.
- Wrong type or grade of fuel used.
- Fault in cold start system.
- Engine temperature is too high.
- In correct valve tip clearances.

The engine runs erratically

- Fault in fuel control.
- Restriction in a fuel system.
- Faulty in fuel lift pump.
- Dirty fuel filter element.
- Restriction air filter/cleaner or induction system.
- Air in fuel system.
- Fault in injectors or injectors are out of adjustment.
- Fault in cold start system.
- Restriction in fuel tank vent.
- Restricted movement of engine speed control.
- Engine temperature is too high.
- In correct valve tip clearances.

Vibration

- Fault in injectors or injectors are out of adjustment.
- Restricted movement of engine speed control.
- Engine temperature is too high.
- Fan damaged.
- Faulty in engine mounting or flywheel housing.

The engine temperature is too high

- Restriction air filter/cleaner or induction system.
- Fault in injectors or injectors are out of adjustment.
- Fault in cold start system.
- Restriction in exhaust pipe.
- Fan damaged.
- Too much lubrication oil in sump.
- Restriction in air or water passage of radiator.
- Engine thermostats are faulty.
- Insufficient coolant system.

Crankcase pressure

- Restriction in breather pipe.

Bad compression

- Restriction air filter/cleaner or induction system.
- Incorrect valve tip clearances.
- Faulty piston rings.

The engine starts and stops

- Dirty fuel filter element.
- Restriction air filter/cleaner or induction system.
- Air in fuel system.
- Bad connection towards oil pressure switch/coolant temperature switch.

Note: Please, look the engine manual for maintenance.

11. ALTERNATOR DESCRIPTION

11.1. General

The alternator fitted on the generator set is of the brushless self-excitation type which eliminates the maintenance associated with slip rings and brushes. The control system, consist of an automatic voltage regulator, protective circuits.

11.2. Construction and Components

The stator core is produced from insulated low loss electrical grade sheet steel laminations. These are built and welded under a fixed pressure to give an extremely rigid core to withstand vibration and load impulses.

The complete wound stator is, after impregnation, pressed into the frame and pinned into position.

The rotor assembly, which comprises the alternator rotating field systems, the exciter rotating diode system and the cooling fan. The complete rotor assembly is dynamically balanced to ensure vibration-free running.

At the drive end of the rotor assembly a cast-aluminum centrifugal fan draws cooling air through screened covers at the non drive end and discharges it through similar side mounted covers at the drive end.

11.3. Operation

The electrical power produced by the generating set is derived from a closed loop system consisting principally of the exciter rotor the main revolving field and the automatic voltage regulator (see Figure 11.1)

The process begins when the engine starts to rotate the internal components of the alternator. The residual magnetism in the main rotor produces a small alternating

voltage (AC) in the main stator. The automatic voltage regulator rectifies this voltage (converts it to DC) and applies it to the exciter stator. This DC current to the exciter stator creates a magnetic field which in turn, induces an AC voltage in the exciter rotor. This AC voltage is converted back to DC by the rotating diodes.

When this DC voltage appears at the main rotor, a stronger magnetic field than the original residual field is created which induces a higher voltage in the main stator. This higher voltage circulates through the system inducing an even higher DC voltage back at the main rotor. This cycle continuous to build up the voltage unit it approaches the proper output level of the generating set. At this point the automatic voltage regulator begins to limit the voltage being passed to the exciter stator which, in turn, limits the overall power output of the alternator.

This build-up process takes place in less than one second.

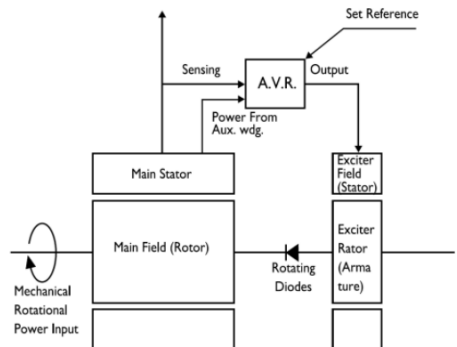

Figure.11.1. Meccalte alternator, operating principles block schematic diagram

11.4. Automatic Voltage Regulator

The Automatic Voltage Regulator (AVR) maintains a no load to full load steady state voltage to tight tolerances.

The AVR has a volt/hertz characteristic which proportionally reduces the regulated voltage at reduced speeds.

11.5. Alternator Insulation Test

Before starting the generating set after installation, test

the insulation resistance of the windings. The Automatic Voltage Regulator (AVR) should be disconnected and the rotating diodes either shorted out with temporary links or disconnected. Any control wiring must also be disconnected.

A 500 V Megger or similar instrument should be used.

Disconnect any earthing conductor connected between neutral and earth and megger an output terminal to earth. The insulation resistance should be in excess of 1 M Ω to earth. Should the insulation resistance be less than 1 M Ω the winding must be dried out.

11.6. Meccalte Alternator Troubleshooting

SYMPTOM	POSSIBLE CAUSE	CORRECTIVE ACTION
Alternator does not excite	Blown fuse Insufficient residual voltage No residual voltage	Replace fuse Increase speed by 15 %. For an instant apply on the (+) and (-) terminals of the electronic regulator a 12V battery with 30 Ω resistor in series respecting the polarities.
After being excited alternator does no excite	Connections are interrupted	Check connection cables as per attached drawings.
Low voltage at no load	Voltage potentiometer out of setting Intervention of protection. Winding failure	Reset voltage Check engine speed Check windings
High voltage at no load	Voltage potentiometer out of setting Failed regulator	Reset voltage potentiometer Substitute regulator
Lower than rated voltage at load	Voltage potentiometer out of setting Intervention by protection Failed regulator Rotating bridge failure	Reset voltage potentiometer Current to high, power factor lower than 0,8; speed lower than 4% of rated speed Substitute regulator Check diodes, disconnect cables.
Higher than rated voltage at load	Voltage potentiometer out of setting Failed regulator	Reset voltage potentiometer Substitute regulator
Unstable voltage	Speed variation in engine Regulator out of setting	Reset voltage potentiometer Substitute regulator

12. STORAGE

In case of the engine is not used for long time, preserve the engine from corrosion, faulty matters in order to run the engine operation easily and keep it long maintenance.

12.1. How to Store the Engine

1- 3 Month Stored Engine

Engine in the box: should be stored in a dry space.

Engine outside : start up the engine more than once in a month.

4-6 Month Stored Engine

Engine should be subject to Internal / external anti-rusting treatment.

Close the Kingston valve of the sea water line tightly, Specially likely to freeze, drain the water of the heat exchanger, inter cooler and marine gear oil cooler, And also last don't forget to detach the sea water pump impeller and preserve it in a dark place.

Procedure of Test Run Stored the Engine 6 to 12 Month

Turn the crankshaft 2 or 3 turns by hand, and check the each line. If the turning is not possible, go check the cause and correct it.

a) Fuel Line

1. Remove the injection nozzle and check its spray pattern.
2. Check the stickiness of injection pump.

b) Cooling Water Line

1. Prepare the solution (water + speed flush).
2. Connect the cooling water in / out line with solution vessel.
3. Start up the engine and do idling with max. rpm 10-15 minutes.
4. Cool down the engine, and drain out the solution completely.
5. Clean out the engine inside with clean water.

c) Oil Line

1. Check the oil leakage and rust.
2. Drain out the engine oil, and replenish the recommended engine oil.
3. Drain the marine gear oil completely and then refill the specified oil (SAE #30) up to the maximum level of the oil dipsticks.

d) Turbo Charger and Air Cleaner

1. Remove the oil delivery pipe, and supply the engine oil into the turbo charger shaft.
2. Clean the air filter element and if worn severely change it new one.

e) Valve Clearance

1. Check the valve clearance and adjust it if necessary.

f) Filter Replacement

1. Replace the fuel / oil filter with genuine ones.

g) Preliminary Test Run

1. After doing (a) through (f), by hand or by starter, turn the engine so that the oil go through every parts of engine.

h) Unload Test Run

Do the un-load test run at idle rpm more than 5 minutes and run at max rpm more than 5 minutes. As doing the un-load test, check the points stated in article.

Check Point When Test Run

1. Check the engine for interference between moving parts and its adjacent parts,
2. During the unload test with max rpm, check for air leakage and Intake exhaust valve.
3. During the unload test, check the cooling system for water leakage
4. During the unload test, check the fuel / oil line for fuel / oil leakage
5. During the unload test with max. rpm, check the combustion sound to decide if it's normal or not
6. As a designated test, accelerate and decelerate the engine 2-3 times, and check the oil supplies the rocker arm,
7. As a designated test, accelerate the engine speed slowly and then fast. Check unusual sound on rotor and bearings.
8. During the unload test with idle rpm and max rpm check the oil pressure is correct for the engine.

Stored the Engine Above 12 Month

1. Replace the engine oil and cooling water
2. The cylinder liners should be inspected by opening

the cylinder head. If no traces of corrosion can be found on the cylinder walls, on the underside of the cylinder head or on the valves,

3. If the rust found, overhaul the engine and follow the sequences for test run
4. if the rust not found the engine, follow the sequence 6 to 12 month
5. If the engine has been stored in an improper manner, i.e. in damp room etc. or considerable longer than 2 years. Please contact the service manager of PROGEN infracone before putting it into operation.

12.2. Alternator Storage

When an alternator is in storage, moisture tends to condense in the windings. To minimize condensation, store the generating set in a dry storage area. If possible use space heaters to keep the windings dry. After removing the generating set from storage, perform an insulation check as discussed in Section 11.5.

12.3. Battery Storage

While the battery is stored, it should receive a refreshing charge every 4 weeks up to a fully charged condition

13. GENERAL PRECAUTIONS ABOUT WARRANTY

Authorized Service Dealer may perform warranty repairs. Most warranty repairs are handled routinely, but sometimes requests for warranty service may not be appropriate. For example, warranty service would not apply if equipment damage occurred because of misuse, lack of routine maintenance, shipping, handling, warehousing or improper installation. Similarly, the warranty is void if the manufacturing date or the serial number on the equipment has been removed or the equipment has been altered or modified. During the warranty period, the Authorized Service Dealer, at its option, will repair or replace any part that, upon examination, is found to be defective under normal use and service. This warranty will not cover the following repairs and equipment:

- Normal Wear: Outdoor Power Equipment and engines, like all mechanical devices, needs periodic parts and service to perform well.

This warranty does not cover repair when normal use has exhausted the life of a part or the equipment.

- Installation and Maintenance: This warranty does not apply to equipment or parts that have been subjected to improper or unauthorized installation or alteration and modification, misuse, negligence, accident, overloading, over speeding, improper maintenance, repair or storage so as, in our judgment, to adversely affect its performance and reliability. This warranty also does not cover normal maintenance such as adjustments, fuel system cleaning and obstruction (due to chemical, dirt, carbon, lime, and so forth).
- Other Exclusions: This warranty excludes wear items such as oil gauges, o-rings, filters, fuses, or injectors etc., or damage or malfunctions resulting from accidents, abuse, modifications, alterations, or improper servicing or freezing or chemical deterioration. Accessory parts are excluded from the product warranty. This warranty excludes failures due to acts of God and other force majeure events beyond the manufacturer's control.

14. GENERAL PRECAUTION

Dear ERK generator set operator. Please take care to the following order to prevent the generator set warranty to become invalid if the warranty period and to ensure trouble-free operation of the generator set with a long life.

1. Maintenance and repair works will not be covered by the warranty certificate. If the invoice or delivery certificate of the generating set is not submitted.
2. The warranty of the generator set will become invalid in case of any intervention of any person other than authorized ERK services or by prior written approval from ERK generation on the generator set for any reason.
3. Control and maintenance works indicated in the periodical maintenance schedule and the operating manual must be carried out completely and timely the failures due to incomplete or untimely maintenance are not covered by the warranty.
4. Generator set should be installed as indicated in the

installation manual otherwise, the problems which are likely to occur will not be covered by the warranty.

5. Customer is responsible for the failures which are likely to occur in case that the diesel oil used contains dirt or water.

6. The oil type indicated in the maintenance manual should be used in the engine otherwise, the failures which are likely to occur will not be covered by the warranty.

7. Batteries will not be covered by the warranty if they are subjected to breakage, excessive acid fill or hardening by leaving uncharged.

8. Don't over crank the generator set , if the generator is not started at the first attempt , wait 10 second and then try to start the engine again , the cranking mustn't be done more than 3 times ,and cranking time have to be less than 10 seconds ,otherwise starter gear could be broken or starter could be burn up. These conditions are not covered warranty.

9. Generator sets, never start or stop the diesel engine when the generating set is under load. Engine should be started and stopped after load is disconnected and the generating set is at idle condition. Otherwise, the valves can be seized, the voltage regulator, transformer and diodes can be broken down. These conditions are not covered warranty.

10. Our company does not take the responsibility of the damages of the automatic generator sets due to over current, low or high voltage.

11. Never remove the battery terminals while the generating set is in use. Even a moment of disconnection can cause damage on the electronic closing relay of the charge alternator and on the electronic engine speed control circuit these conditions are not covered by the warranty.

12. Failures due to overload and unbalanced load in excess of the generating set power (such as alternator

and contactor failures) are not covered by the warranty.

13. When the manually operated generating set is started up, it should be warmed by operating at idle for 5 minutes. When stopping the diesel engine, it should be unloaded and then continued to be operated for cooling for 5 minutes before stopping. Otherwise problems which are likely to occur will not be covered by the warranty

14. Never run the Genset for a long time under the 30% of prime power , the problems which are likely to occur will not be covered by the warranty

15. Use only original spare parts. The problems which are likely to occur will not be covered by the warranty

16. The first starts of the Gensets have to be done by ERK Authorized Services; otherwise Genset warranty will be invalid.

17. Any project or additional equipments couldn't be done or installed to the Genset within the warranty period. If those plans (synchronizations, additional control panel, panel, transfer panel etc.) are done without notifying the ERK Authorized services, Genset won't be covered by warranty.

18. Warranty period of product 12months or 1000 hours of running time whichever expires first. The warranty period begins with the shipment date of product.

15. CUSTOMER RESPONSIBILITY

1. The First Start is only valid for the location where the Genset is installed ,if the location of the Genset is going to be changed , the Genset has to be controlled and tested by ERK Authorized services again. Warranty of the generator set will become invalid if the first start and controls are done by any person other than authorized TMGPOWER services .The customer will bear the cost of Second Start.

2. Control and maintenance works indicated in the periodical maintenance schedule and the operating manual must be carried out completely and timely by

Authorized services for a fee. The maintenance schedule and Manuals are given to the customer with the Genset. If these Manual and schedules are lost, customer has to have a new one.

3. Other than manufacturing defect, Customer will bear the fee of all maintenance, troubleshooting and problems

4. If the Gensets won't be started more than 2 Months, These Gensets have to be stored as mentioned in the Manuals. The necessary information and help can be provided from PROGEN Authorized services

5. The conservation (storage) of the Genset have to be done by PROGEN Authorized services, If the Genset is in warranty.

6. If the customer wants service guy work overtime, customer has to bear the cost of overtime pay.

7. Customer has to bear the cost of operations, installations and structures such as access doors, barriers, walls, railings, floors, ceiling, or the likes, rental cranes or the likes of cranes, built ramps or the likes, trailers or protective structures

8. Customer have the right of asking and investigating the service guy authorization, it is also a customer duty.

9. Customer has to keep the Warranty Certificate and the First Start documentation to have warranty service, for this reason, this documentation should be kept into Generator Room within easy reach.

10. Genset room dimensions have to be according to norms, adequate ventilation and exhaust outlet have to be provided by customer.

11. Mains contactors are chosen according to Generator sets nominal power, PROGEN is not responsible for the failures which is caused by over current drawn by mains.

12. Main's lower and upper limits are determined so as to Gensets and customer's plant will work properly. Changing the mains voltage limits if requested by the customer, the customer is responsible for all faults resulting from this change, this change can be made by writing a report on the customer undertakes.

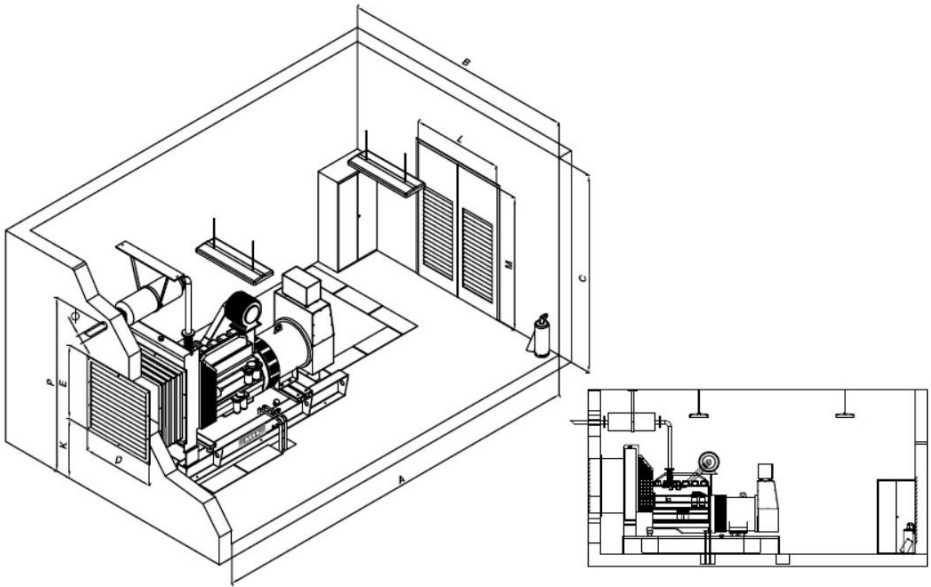

Figure 15.1. Open type generator room layout

AIR EXHAUST

Hot air from the generating set is discharged from the room through a hot air duct (optional) fitted in an opening in the wall the same size as the duct. The hot air discharge opening is protected from any obstruction, penetration or inflation of foreign elements by a metal louvre. Use a neoprene foam to seal the hot air discharge duct in the wall. The exhaust pipe is fitted in the hot air discharge duct. Hot air from the radiator passes through the canopy roof.

AIR INLET

Air inlet louvre on door or Wall. AIR INLET SURFACE minimum $\times 2$ the air exhaust arc

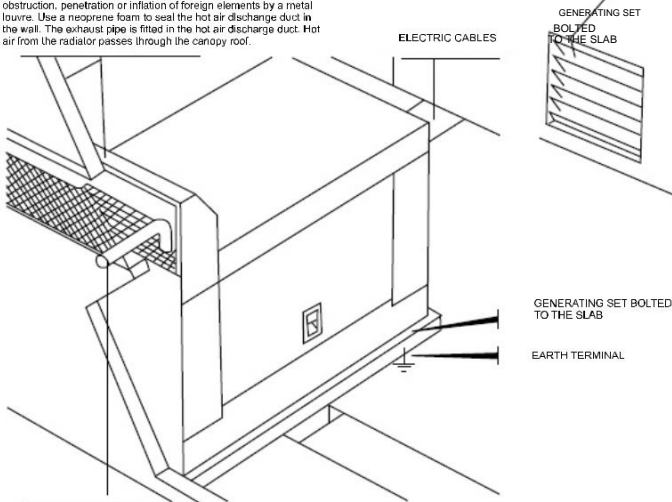

EXHAUST GASES DISCHARGE OUTSIDE THE ROOM

When the original piping must be extended, should be mounted on an efficient suspension bracket fitted and muffler belows between piping and muffler. It must never rest on the engine or muffler.

Figure 15.2. Soundproof type Generating set room

