

“SKB Elektronmash” TDV



LINE SMOKE DETECTOR

CV212-14

User Manual

AKPI.425231.001RE

www.bezpeka-shop.com

CONTENT

1	DESCRIPTION	4
1.1	APPOINTMENT	4
1.2	SPECIFICATIONS	5
2	INSTALLATION	6
3	OPERATION OF THE DETECTOR	8
4	CONNECTION AND COMMISSIONING	11
5	INSPECTION FUNCTIONING	15
6	MAINTENANCE	16
	APPENDIX A. General view and overall dimensions of the transmitter and receiver	17
	APPENDIX B. Transmitter and receiver mounting dimensions	18
	APPENDIX C. Marking and connecting elements	19

CERTIFICATION INFORMATION

The line smoke detector CV212-14 is certified in accordance with the requirements of the standard EN 54-12:2015 Fire detection and fire alarm systems. Part 12: Smoke detectors. Line detectors using an optical light beam.

Quality Management System at the factory is certified in accordance with the requirements of the standard ISO 9001.

Copies of certificates are on the site <http://www.chelmash.com.ua>

MANUFACTURER

"SKB Elektronmash" TDV
265B Golovna str.,
Chernivtsi,
Ukraine 58018
tel/fax (03722) 40639
e-mail:spau@chelmash.com.ua
<http://www.chelmash.com.ua>
Version 001en

The user manual is intended for studying the device, operation, install and commissioning of the line smoke detector CV212-14.

The following conventions are used in this manual:

- c.i.e. - control and indicating equipment;
- IL - transmitter;
- IR - infrared;
- PDU-L - remote control unit;
- PL - a receiver;
- UPS - uninterruptible power supply.

1 DESCRIPTION

1.1 APPOINTMENT

Line smoke detector CV212-14 (hereinafter the detector) consists of a receiver PL and a transmitter IL. To control the operation modes, the PDU-L remote control unit is used.

Detection of the products of combustion is performed by controlling the level of attenuation of the infrared beam between a transmitter IL and receiver PL (hereinafter transmitter and a receiver, respectively).

The detector is designed to work with fire alarm and fire alarm devices in fire alarm and fire extinguishing systems.

The detector is designed to detect combustion products in enclosed spaces, indoors or in places that prevent moisture from entering it.

The installation locations for the detector defined according to the planning information.

Installation should be performed by a specialist in compliance with safety regulations.

The detector is not a source of danger for people or for protected material values (including in emergency situations).

In accordance with EN 62471, "Photobiological Safety of Lamps and Lamp Systems", the linear smoke detector falls into the "Exempt Group".

1.2 SPECIFICATIONS

Range of action, m,	range "10-100"	10...100
	range "1-15"	1...15
Settable thresholds, dB		1, 2, 3
(approximately 15, 30 and 45% absorption by smoke)		
Response time in the mode "ALARM (FIRE)", s, no more than		30
Readiness time, s, no more than		10
Power disruption time to reset, s, not less than		1
Operating voltage of transmitter and receiver, VDC		18...30
The transmitter and receiver are insensitive to the polarity of the supply voltage		
Operating current of transmitter or receiver, mA, up to		8
Receiver current in mode "ALARM", mA, not less than		18
The maximum switched voltage by contacts		
"ALARM", "FAULT", V		100
The maximum switched current by contacts		
"ALARM", "FAULT", A		0.15
Maximum resistance of closed contacts of relay "FAULT", Ohm		30
Operating distance of remote control, m		from 1 to 20
The deviation of the optical axis of the transmitter		
relative to optical axis of the transmitter-receiver, degrees, not more than		
during installation		±5
during operation		±2
The deviation of the optical axis of the receiver		
relative to optical axis of the transmitter-receiver, degrees, not more than		
during installation		±15
during operation		±2
Operating conditions of the transmitter, receiver:		
Ambient air temperature, degrees Celsius		from minus 5 to 40
Relative air humidity at 25°C, %, up to		98
Atmospheric pressure of air, kPa		84...107
Degree of protection of the detector and receiver shell		IP40
Working position any		
Working hours round-the-clock continuous		
Service life, years		10

2 INSTALLATION

ATTENTION!

Detector components should be taken only beyond the side surfaces of their bodies, avoiding touching the outer optical elements (filters).

A protective film with optical elements to remove the least immediately before latching operation threshold on site.

2.1 The appearance and dimensions of the receiver and the transmitter are shown in Appendix A.

2.2 Installation of transmitters and receivers should perform on fixed structures and components of buildings on one optical axis towards each other.

The mounting surface for the detector's components must be firm and vibration-free. Metal supports that may be affected by heat or cold are unsuitable for the installation.

Fastening base receiver and transmitter to the surface and perform two fasteners (bolts, screws, dowels, not supplied) in accordance with Appendix B.

Pass the wires through the cable glands of the base (see Appendix A) and connect them to the screw terminals of the connectors from the detector set. Tighten the nut of the clamp of the seal only after passing all the wires.

It is possible to insert the wires from behind, for which it is allowed to drill the holes of the correct size at the base of the detector components.

The side of the detector's receiver, on which the LED and the IR receiver of the remote control is located, is deployed in the direction from which the LED and the IR receiver of the detector's remote control are visible to the service personnel (it is recommended to point downwards).

The side of the detector's transmitter, on which the LED is located, should be deployed in the direction from which the LED of the transmitter is visible to the service personnel (it is recommended to point downwards).

After installation, provide for measures to isolate the places of entry of wires to protect against moisture, dust, penetration of insects.

2.3 Installation angle should comply with the maximum tolerances in any planes relative to the optical axis of transmitter and receiver.

At installation, the maximum deviation in any direction from the central optical axis should not exceed 5 degrees for transmitters and 15 degrees for receivers as shown in Figure 1.

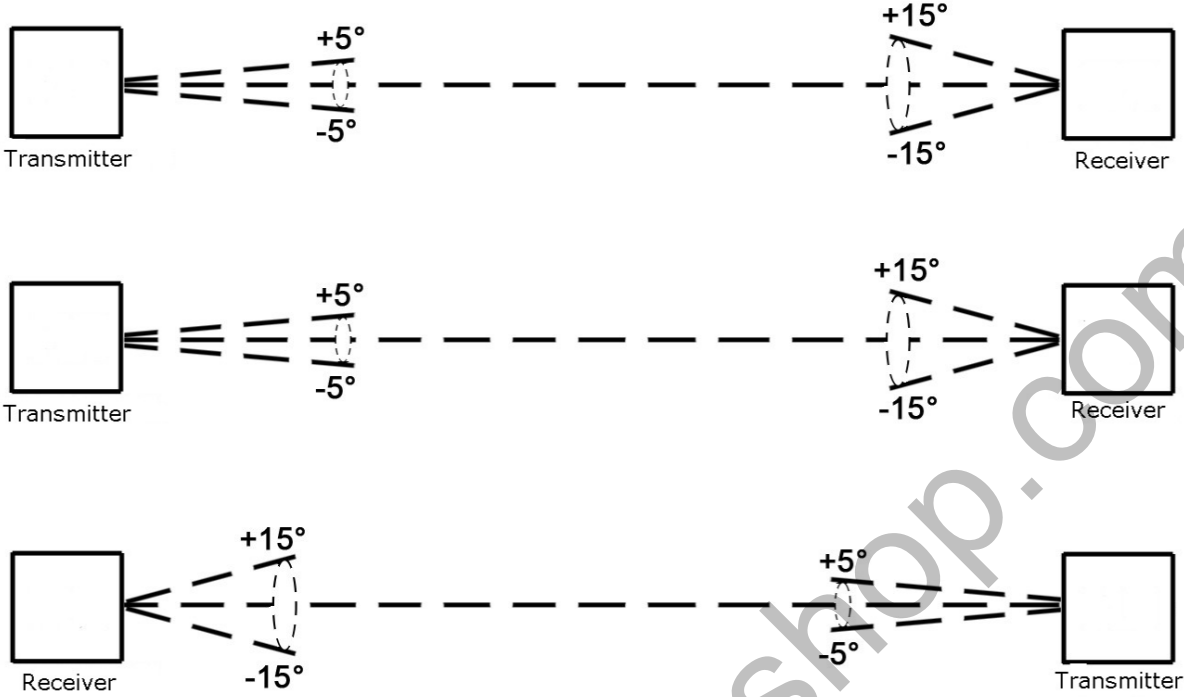

Figure 1

After fixing of a transmitter and receiver durable angular deviation from the originally installed position should not exceed 2 degrees. This should be considered when installing the detector components on structures that can deform with time.

2.4 The line of sight between the transmitter and the receiver always has to be clear and may not be interfered by moving objects (e. g. overhead crane).

Heat accumulation under the roof may prevent smoke from rising up to the ceiling. Thus, the detector must be mounted below the expected heat accumulation.

Since the smoke from a fire does not simply rise straight up, but rather spreads like a mushroom cloud (depending on air current and accumulation), the monitoring range is much greater than the diameter of the IR beam.

The maximum distance between two detectors with parallel IR beams is determined by national standards. The minimum distance between the two detectors is not regulated.

The centre line of the monitoring beam may not be closer than 0.25 m to walls, ceilings, furniture or stored goods.

With a room height of more than 12 m, it is recommended to install a second monitoring level on which the detectors are arranged offset to the first monitoring level.

It is allowed to operate the detector through a glazed window or laminated glass, with the angle between the normal to the base and the normal to the glass should be more than 10 degrees.

The transmitter and the receiver are usually installed at the same height and aligned with one another. The wide angle of view of the transmitter and receiver allows for an easy installation and for a reliable long-term stability.

The detector must be mounted in a position where the receiver input window is not exposed to direct sunlight or artificial light. Normal ambient light does not affect the operation of the receiver.

3 OPERATION OF DETECTOR

3.1 Operation of transmitter IL

The transmitter operates continuously after power is applied and the readiness time is complete. After the power is applied to confirm and verify the LED itself, the transmitter gives one flash with duration of 1 second. The transmitter is monitored by a green LED on its side, which should flash for a short time (0.25 s) every 5 seconds.

3.2 Operation of receiver PL

The receiver operates continuously after power is applied and the readiness time is complete. After the power is applied to confirm and verify the LED itself, the receiver gives one flash with duration of 1 second.

The receiver outputs a signal "ALARM (FIRE)" by increasing the current consumption and the "ALARM" output of the receiver is intended for the transmission of an alarm signal by closing the contacts of the built-in relay (dry contact; in the quiescent mode, the contacts are open).

The "FAULT" output of the receiver is intended for the transmission of a fault signal by opening the contacts of the built-in relay (dry contact; in the quiescent mode, the contacts are closed).

The states and indications of the transmitter IL and receiver PL are given in Table 1.

A malfunction is one of the following:

- high power voltage;
- low power voltage;
- the level of the light background exceeds the maximum allowed;
- the level of interference exceeds the maximum allowed;
- the signal level is higher than the allowable level;
- the signal level is less than the allowable level.

Power and background malfunctions are reset automatically after the causes have been eliminated, as well as from the remote control or power interruption; the remaining faults can be cleared either by the remote control or by interrupting the power.

3.3 Remote control unit PDU-L allows:

- set the test signal "ALARM-TEST" (button "3")
- set the test signal "FAULT-TEST" (button "2");
- cause the receiver to its initial state (reset) when a fault and/or the state of the test fire (button "1");
- set the thresholds for operation during memorization.

3.4 The test mode "ALARM-TEST" (set with the PDU-L) simulates the alarm condition. This mode can be reset both with the PDU-L and the power supply of the detector's receiver. The alarm on the working signal ("true fire") is reset only by interrupting the power supply of the detector's receiver.

3.5 The test mode "FAULT-TEST" (set with the PDU-L) simulates the fault condition. This mode can be reset both with the PDU-L and the power supply of the detector's receiver.

Table 1

Power	Condition of receiver	The status of the indication LEDs on the receiver and on the transmitter	ALARM contacts of detector's receiver	FAULT contacts of detector's receiver	Current consumption of detector's receiver
off	off	off	open	open	-
on	FAULT	Double flashes approximately 1 time per second	open	open	no more 8 mA
on	QUIESCENT	Flashes every 5 seconds At the transmitter of the detector - single. At the detector's receiver: Single - 1 dB threshold; Double - 2 dB threshold; triple - 3 dB threshold.		closed	no more 8 mA
Power	Condition of receiver	The status of the indication LED on the receiver	ALARM contacts of detector's receiver	FAULT contacts of detector's receiver	Current consumption of detector's receiver
on	REMEMBERING	At the beginning of memorization, regular flashes of about 25 seconds, then a pause of about 10 seconds, a total storage time of about 45 seconds, then three flashes with duration 1 second upon successful memorization. Errors of memorization - double flashes with a weak signal.		closed	no more 8 mA
on	ALARM	Lights up continuously	closed	closed	not less 18 mA
on	ALARM-TEST	Lights up continuously	closed	closed	not less 18 mA
on	FAULT-TEST	Double flashes approximately 1 time per second	open	open	no more 8 mA

4 CONNECTION AND COMMISSIONING

4.1 Connections

The connecting elements of the receiver and the transmitter are shown in Appendix C. To the connectors (are included in the detector set) it is possible to connect a wire with a cross-section from 0.2 to 1.5 square mm.

4.2 Transmitters connecting

The transmitter can be powered by an uninterrupted power supply of a (21...30) VDC or from zone of c.i.e. (it is recommended for one transmitter in the zone; it is allowed for two at a current limit of the zone of at least 25 mA). The connection methods for both options are shown in Figure 2.

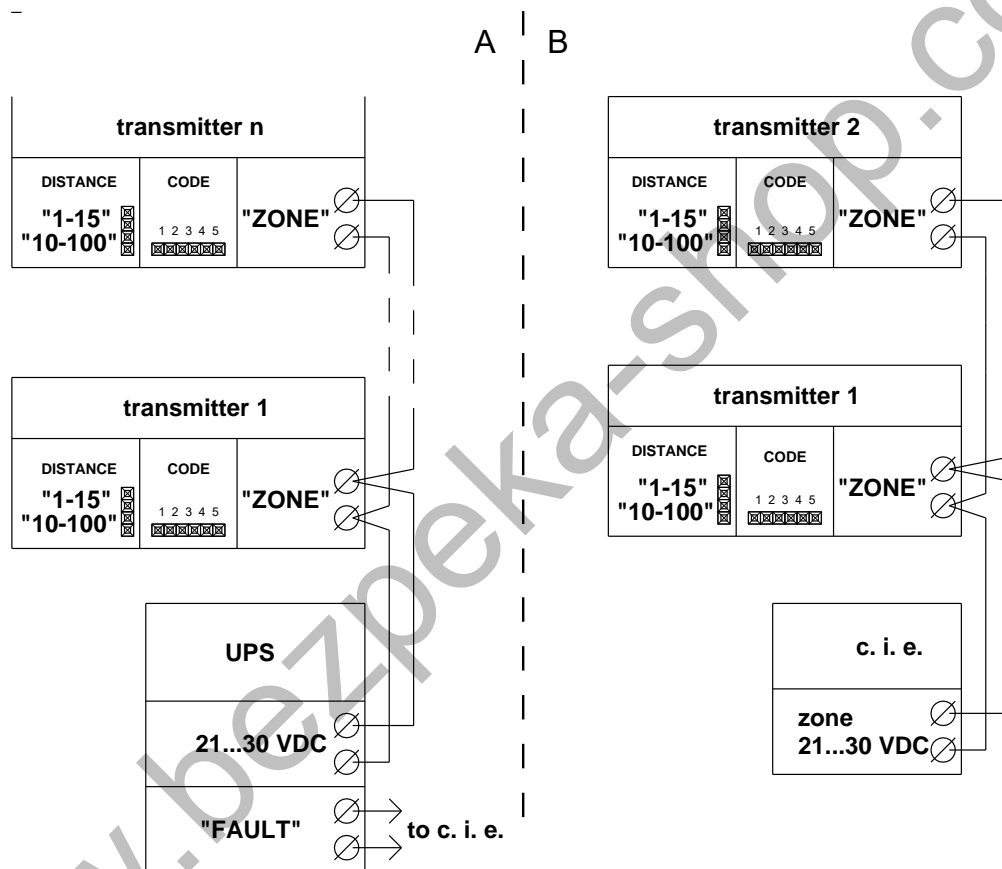

Figure 2

It is possible to connect several transmitters to a single UPS within the power supply output current I_{out} (A); maximum number of transmitters $n=80 \cdot I_{out}$.

It is recommended to use UPS with the output "MALFUNCTION" for monitoring the condition of the UPS.

The total resistance of the wires should not exceed 250/n ohms.

Transmitter's green LED should briefly flash 1 time per 5 seconds.

4.3 Receivers connecting

Receivers are connected to the zones of c.i.e. only one at a time and transmit the status of "ALARM (FIRE)" by increasing current consumption and closing the "ALARM" contacts. Connection to the alarm loops is shown in Figure 3.

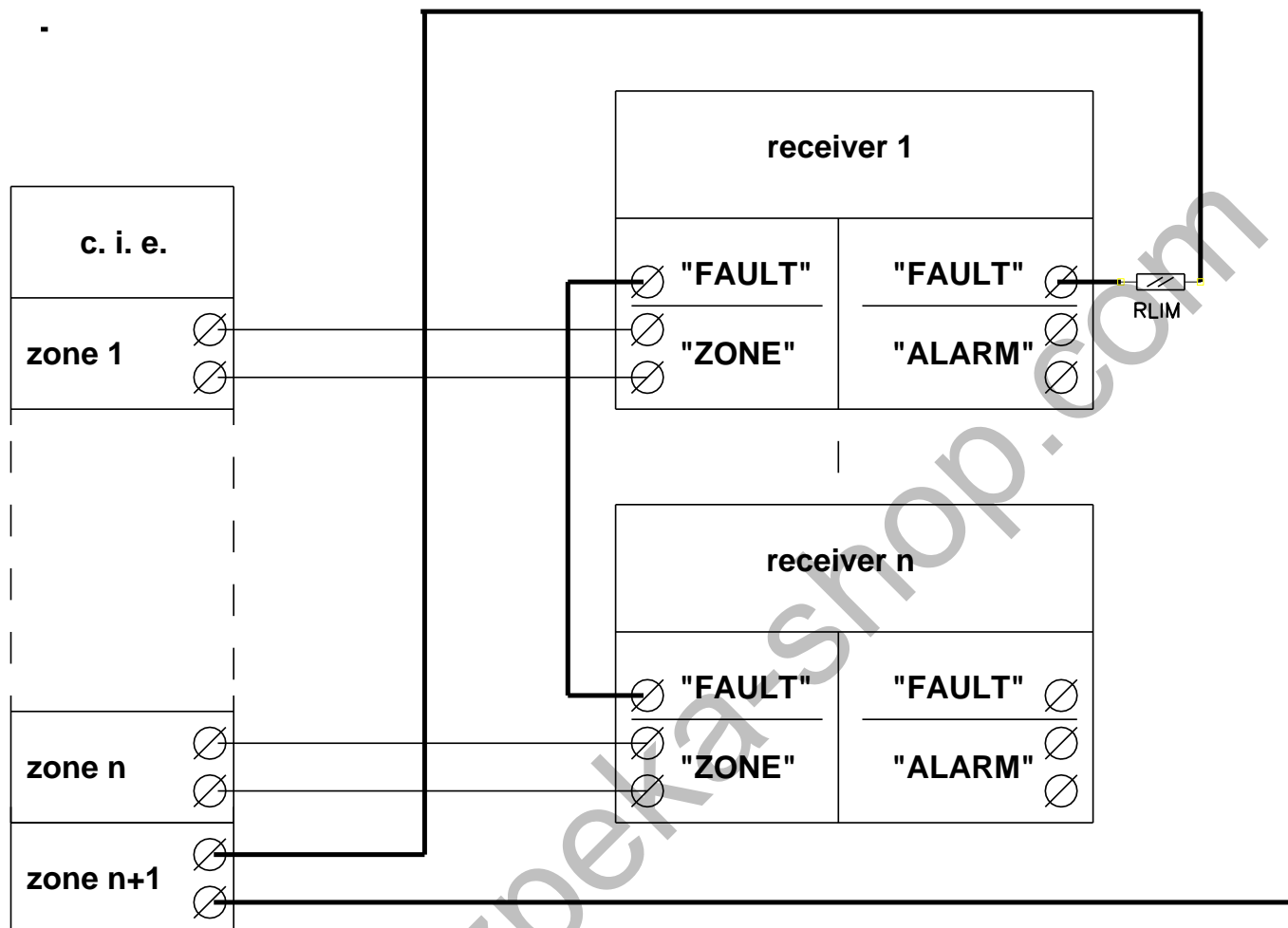

Figure 3

The total resistance of the wires should not exceed $250/n$ ohms.

The output "ALARM (FIRE)" is galvanically isolated (dry contact). In the quiescent mode (as well as "FAULT" and "FAULT-TEST") contacts are open, in the "ALARM (FIRE)", "ALARM-TEST" modes contacts are closed.

When using the "ALARM" outputs, each of them is connected to one alarm loop in accordance with the description for the device used.

Alternative option is to connect the outputs "ALARM" of all receivers to one zone with current-limiting resistors RLIM at the every receiver and terminating resistor RT on the farthest receiver (Figure 4). In this case, the alarms on all the connected receivers will be processed by OR, that is, if it is alarm at least in one

receiver which is connected, a common signal is alarm. If it is no alarm at all receivers that loop current will be limited by the terminating resistor R_T and wire resistance and zone to be normal. In this case it is possible to connect all receivers to the power supply within the power supply output current I_{out} (A); maximum number of receivers $n=80 \cdot I_{out}$.

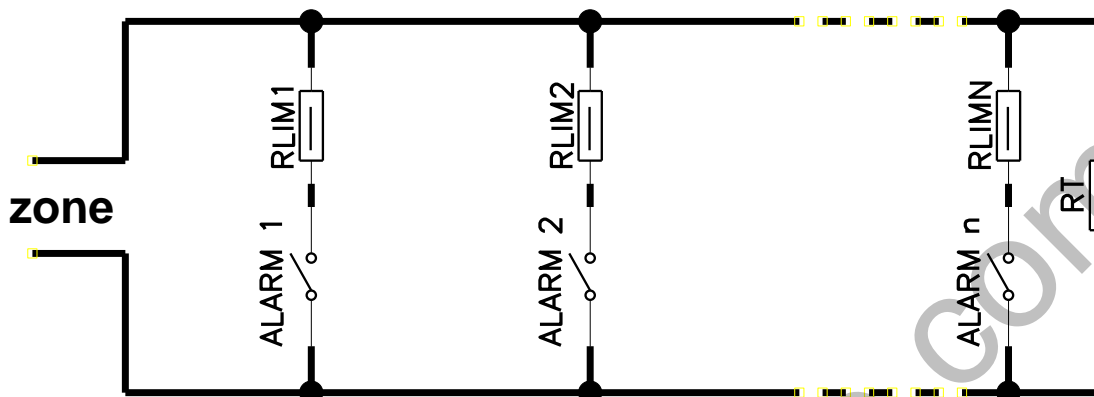

Figure 4

The output "FAULT" is galvanically isolated (dry contact). In the quiescent mode (as well as "ALARM (FIRE)" and "TEST FIRE") contacts are closed, in the "FAULT", "FAULT-TEST" modes contacts are open.

The output "FAULT" is connected to the zone (**zone n+1** in the Figure 3) through the current-limiting resistor $RLIM$ and in case of a fault, this loop is set to an open.

It is possible to connect the outputs "FAULT" of all receivers to one zone in series with a current-limiting resistor at the farthest receiver (as in Figure 3). In this case, the faults on all the connected receivers will be processed by OR, that is, if it is faulty at least in one receiver which is connected, a common signal is faulty and will in breakage. If it is no fault at all receivers that loop current will be limited by the load resistor set ($RLIM$ in Figure 3) and wire resistance and zone to be normal.

The total resistance of the wires used to connect "FAULT" outputs, should not be in place with the current-limiting resistor exceed resistance limiting current standards for the zone.

If it is necessary to distinguish between the break of the loop and the malfunction of the receivers and monitor the condition of the actual fault zone, the

connection diagram should correspond to Figure 5, where RSHUNT is a shunt resistor, RT is a terminating resistor.

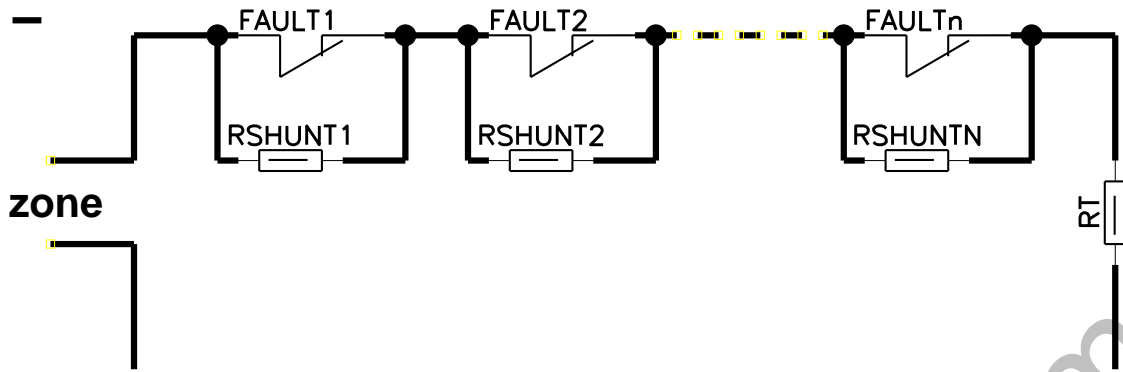

Figure 5

In this case, termination of the zone wires will give a fault in this zone in the c.i.e., and the failure of the receiver will give an alarm in this zone.

Calculation of the values of the resistors is made according to the documentation for the instruments used.

4.3 Comissioning

4.3.1 When the distance between the transmitter and receiver less than 12 m, jumper "1-15/10-100" on the transmitter should be set to the position "1-15" (see Appendix B). If the distance is more than 10-12 m, set the jumper to the "10-100" position.

4.3.2 When used in the same room more than one linear detector must be on adjacent transmitter and detector zones it set **different** codes jumper setting (Jumpers) on the "CODE" fork contacts in accordance with Table 2 and Appendix C.

Table 2

Jumper on contacts	1 and 2	2 and 3	3 and 4	4 and 5	5 and 6	Not installed
Code	1	2	3	4	5	6

4.3.3 Remembering (setting detector in working condition)

4.3.3.1 Power on the transmitter (it is possible to supply power to the entire transmitters, installed in this room, simultaneously). Supply power only to the receiver, with which the work is directly performed, the receivers of all other detectors should be turned off. This is necessary to prevent changes in the settings of receivers, with which the work is currently not carried out.

After applying power to the receiver, wait for about 10 s. The red LED on the receiver should flash with a short single pulse with a period of 5 s (in the delivered state).

4.3.3.2 Press the "F/C" button on the PDU-L - the red LED of the remote will go in the double's treatment outbreaks (mode is active 8 s).

Send remote control PDU-L to the remote control IR receiver at the detector receiver and by pressing the corresponding button set the threshold detector according to the draft (1 dB - button "1", 2 dB - button "2", 3 dB - button "3").

Recommended values the thresholds depending on the working distance are 1 dB at a distance of up to 20 m, 2 dB at a distance of 20 to 40 m, and 3 dB at a distance of more than 40 m.

If the memory is successfully completed, the red LED should give 3 flashes with a duration of 1 second every. The detector is ready for operation.

If an error of remembering that may occur if:

- background level exceeds the maximum allowed;
- supply voltage does not correspond to a nominal value;
- the level of interference exceeds the maximum allowed;
- the signal strength is less or more than the allowable value

the red LED should go into the dual flash mode with a repetition period of about 1 s, indicating a malfunction.

It is necessary to eliminate the factors that prevent the memorization - control distance between the transmitter and receiver and the jumper on the transmitter in the appropriate position, to ensure absence and obstacles overlapping their line of sight between the transmitter and receiver or presence reflective (specular) surfaces near the optical axis between transmitter and receiver.

After elimination the detected reasons, repeat the memorization with the desired threshold.

If the memorizing is successful, the detector goes into standby mode, and by specifying the set threshold for the number of flashes with a period of 5 seconds (see Table 1).

5 INSPECTION FUNCTIONING

5.1 The functioning of the detector receiver can be checked without connecting it to the system. To do this, it is necessary to apply the supply voltage to the terminals "ZONE" receiver (constant voltage 18...30 VDC).

Press "3" button on PDU-L - receiver should go into a state of "ALARM (FIRE)" (see Table 1), and red LED of a receiver must continuously shining.

Post a receiver command "RESET" by pressing the button "1" on the remote control PDU-L.

The receiver's red LED should go out.

5.2 Checking the alarm system

The detector and the system must stand on quiescent condition.

Press button "3" on the remote control PDU-L - receiver should go into a state of "ALARM (FIRE)" (the test), the red LED on the receiver must continuously shine. The system must switch over to the "ALARM (FIRE)" in a zone, which is connected to the detector.

Reset fire on the c.i.e. The fire alarm system and the detector should be in the quiescent condition.

5.3 Signal check on signal

Cut off **half of the** input filter of the receiver with an opaque flap of any material. The receiver and the system must go to the "ALARM (FIRE)" state in the zone to which this detector is connected.

Reset the fire at the c.i.e. The fire alarm system and the detector should be in the quiescent condition.

5.4 Check for a fault signal

Cut off **entire** receiver by a shield of any opaque material. The receiver must go into fault mode (see Table 1).

6 MAINTENANCE

Service should be conducted at least once every six months with the detectors disconnected, so as not to cause false alarms.

Service consists in removing dust and dirt from the filters and housings on the transmitter and receiver. Cleaning optical surfaces should be done with a soft, lint-free cloth moistened in water (if contamination of optical surfaces is not removed by a damp cloth).

ATTENTION! Do not use acetone-containing liquids and other solvents that can damage the surfaces of optical elements.

www.bezpeka-shop.com

APPENDIX A

General view and overall dimensions of the transmitter and receiver

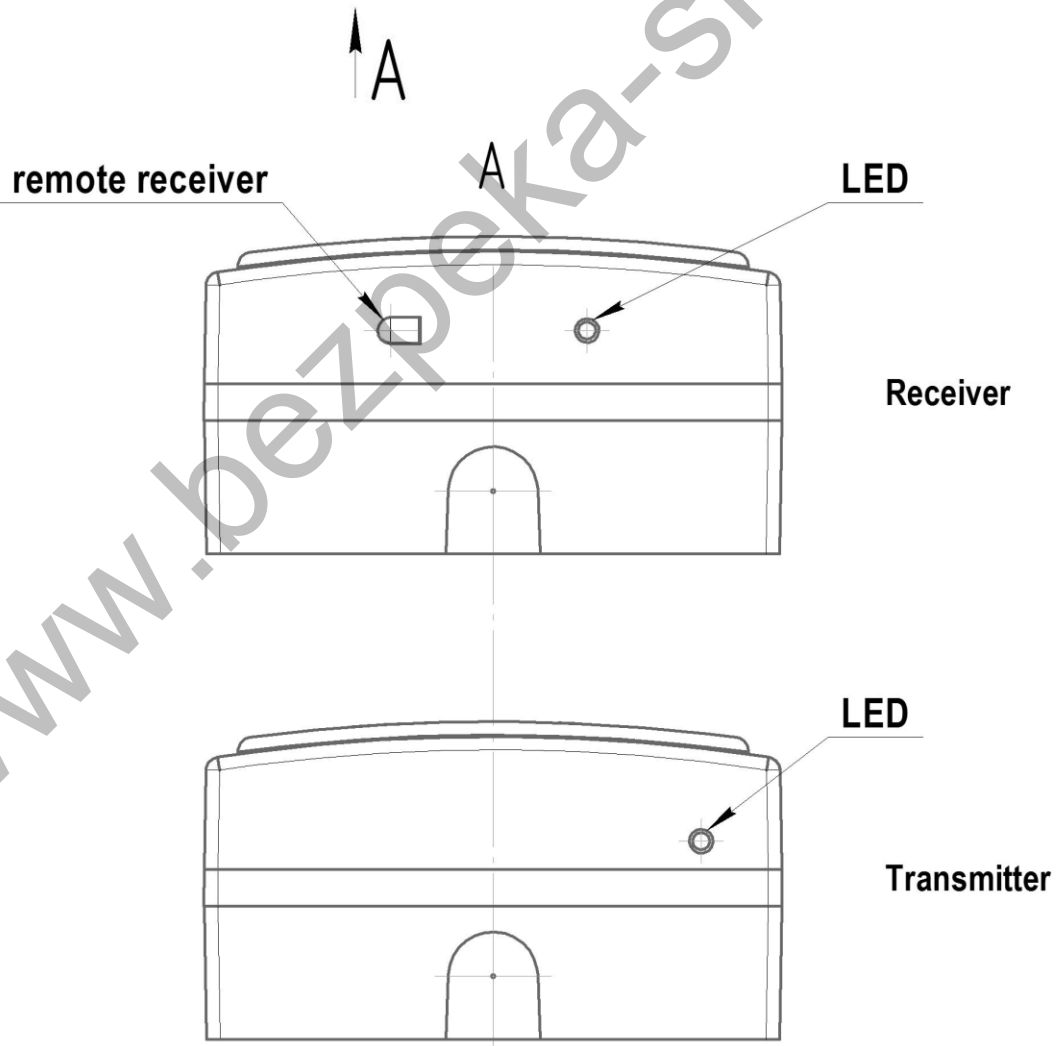
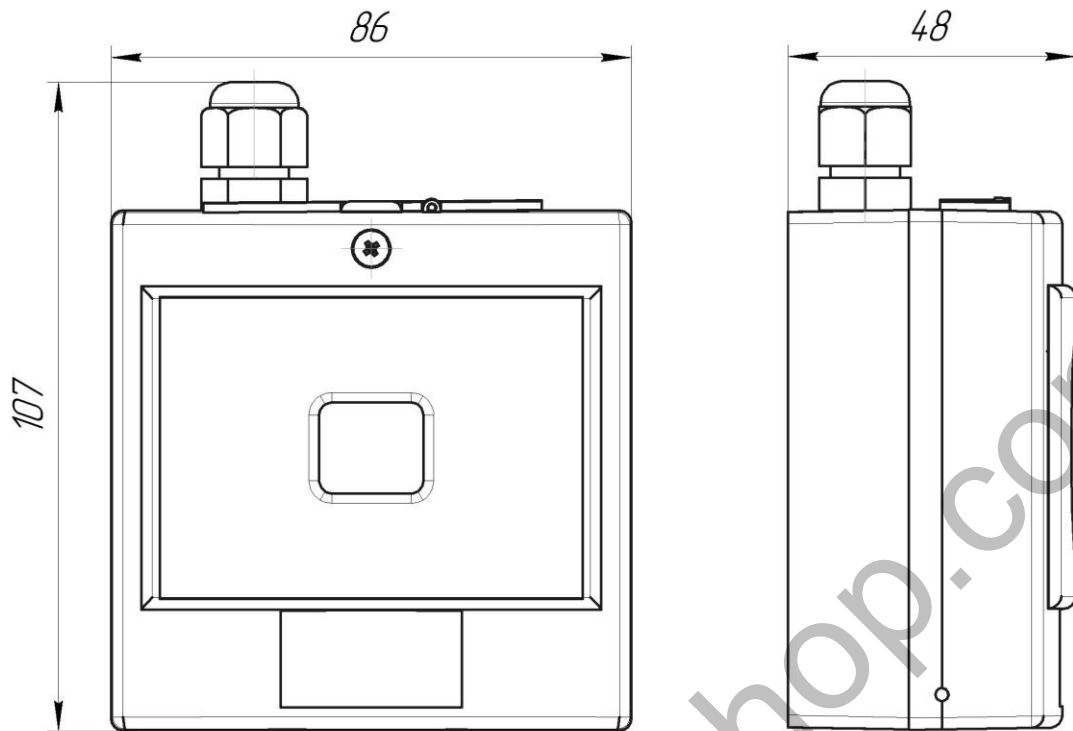

APPENDIX B

Transmitter and receiver mounting dimensions

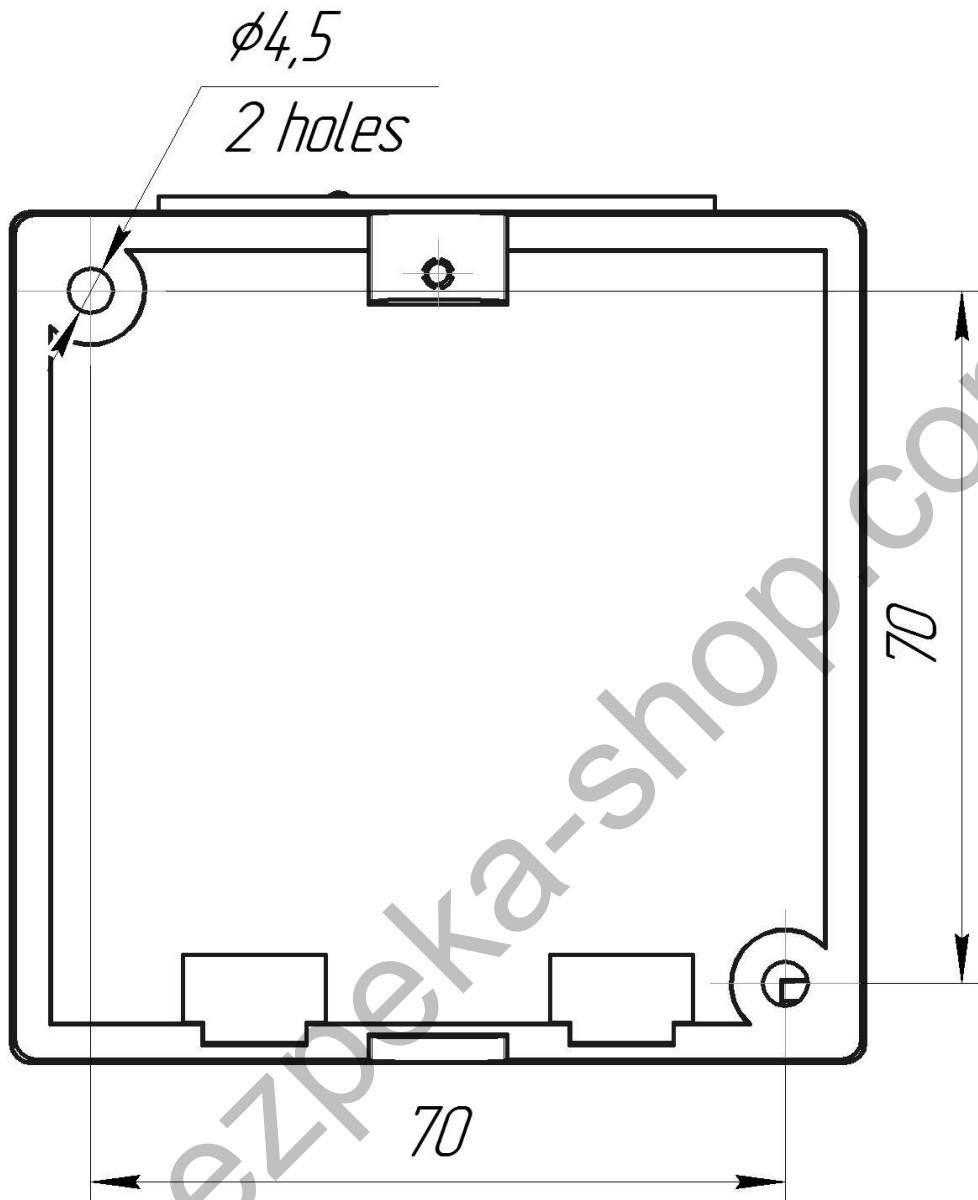

APPENDIX C

Marking and connecting elements (cable glands are not shown)

CODE

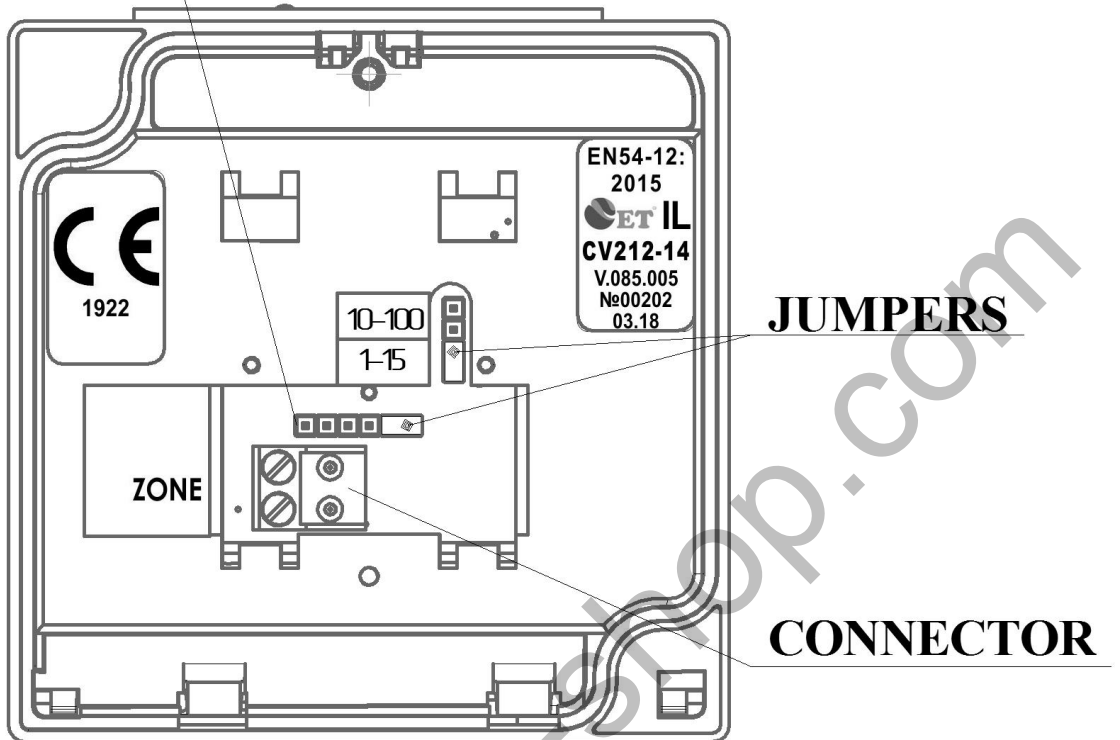

Transmitter IL (position of jumpers is shown conditionally)

CONNECTORS

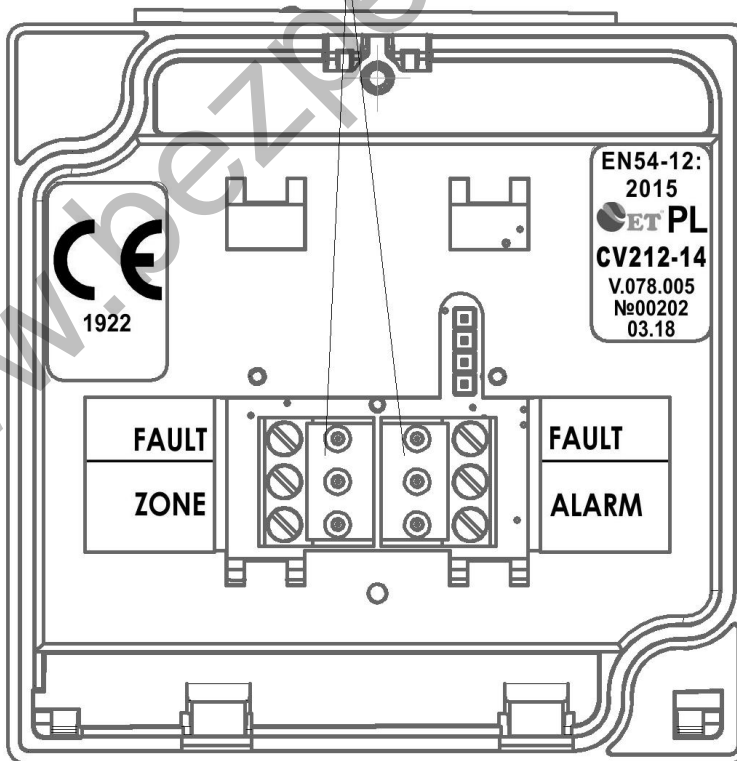

Receiver PL

www.bezpeka-shop.com

MANUFACTURER
"SKB Elektronmash" TDV
Golovna str., 265B,
Chernivtsi,
Ukraine 58018
tel/fax (03722) 40639
e-mail: spau@chelmash.com.ua
<http://www.chelmash.com.ua>
Version 001en